

Pro



Sport

USERS HANDBOOK

This handbook refers to all Pro-Sport models

PLEASE READ THIS MANUAL BEFORE USING YOUR NEW RIFLE, IT CONTAINS IMPORTANT SAFETY INFORMATION AND INSTRUCTION ON ADJUSTMENT AND MAINTENANCE.



*** THE SAFETY CODE ***

- 1 - ALWAYS TREAT AN AIR RIFLE AS IF IT IS LOADED.
- 2 - NEVER POINT AN AIR RIFLE AT ANYONE EVEN IF IT IS NOT LOADED.
- 3 - NEVER LEAVE THIS AIR RIFLE UNATTENDED WHEN IT IS COCKED OR LOADED.
- 4 - ALWAYS BE SURE OF WHAT LIES BEYOND YOUR TARGET.
- 5 - ALWAYS CONDUCT YOURSELF IN A SPORTSMAN-LIKE MANNER.

ALWAYS BE AWARE THAT YOUR ACTIONS WILL BE UNDER THE SCRUTINY OF OTHER MEMBERS OF THE PUBLIC WHO MAY NOT SHARE YOUR ENTHUSIASM FOR AIR WEAPONS. BAD PRACTICES PROMOTE BAD PUBLICITY. DO NOT JEOPARDISE YOUR FUTURE ENJOYMENT BY MISUSING THIS WEAPON.

THIS RIFLE HAS BEEN SET UP AND TESTED ON AIR ARMS PELLETS (SEE BACK PAGE). IF ANY OTHER MAKE OR TYPE OF PELLET IS USED, THE RIFLE MUST BE RE-TESTED TO ENSURE THE MUZZLE ENERGY IS WITHIN THE LEGAL LIMIT.

WARNING! - UNAUTHORISED DISASSEMBLY OF THIS RIFLE WILL INVALIDATE THE MANUFACTURERS WARRANTY.

IMPORTANT INFORMATION, PLEASE READ

Before leaving the factory this rifle was Q.A. inspected and test fired using Air Arms PELLETS to check operation and final adjustment.

It was dispatched in a sealed purpose designed box with a contents label on the lid. Air Arms may not be responsible for any damage to the contents or missing items if the box is not original, if it is damaged or the seals are not intact.

Air Arms cannot be held responsible for damage or missing items due to transit damage, mishandling or being tampered with after leaving the factory.

If this rifle is not received in the original box with the seals intact, please examine carefully for any damage, missing tools or documentation.

In the first instance any problems or complaints regarding this product should be referred to the supplier.

To maintain this rifle in good working order it should be serviced annually by a competent gunsmith, your supplier may be able to provide this service or contact air arms.

A reasonable amount of advice will be provided to enable the end user to service their own rifle, however this is at the discretion of air arms and may not be given in all cases.

The velocity of this rifle has been set using air arms hunter pellets. If any other make or type of pellet is to be used, the rifle must be re-tested with the pellet that is to be used to ensure the muzzle energy is within the limits determined by current legislation.

Contact your supplier or air arms for any advice on this matter.

CHECKING VELOCITY

1 Use a reliable chronograph to check velocity, (the formula below requires the reading to be in feet per second - FPS)

2 Use fine measurement scales to weigh the pellet, If scales are unavailable the pellet weight may be stated on the pellet container lid or contact the supplier. (The formula requires the weight to be in grains). To convert from grams to grains multiply by 15.432, i.e. 0.69 grams x 15.432 = 10.65 grains.

3 To find the muzzle energy in ft/lbs use the formula $(FPS \times FPS \times Grains) / 450240$, i.e. $(700 \times 700 \times 10.65) = 5218500$ divide by 450240 = 11.59.

CURRENT LEGISLATION LIMITS NON-FAC HOLDERS TO AIR RIFLES WITH A MAXIMUM OF 12ft/lbs MUZZLE ENERGY.

WARNING! IT IS A VERY SERIOUS OFFENCE TO BE IN POSSESSION OF AN AIR RIFLE THAT YOU ARE NOT CERTIFICATED FOR. CONVICTION CAN RESULT IN CONFISCATION OF YOUR RIFLE, A HEAVY FINE OR IMPRISONMENT, EVEN A COMBINATION OF ALL THREE.

Caution: This air rifle is not a toy and may cause death or serious injury if misused or used carelessly. Read all instructions before using. This air weapon requires adult supervision if the user is under 14 years old. The supervisor must be at least 21 years old. The purchaser and user have the responsibility to conform to all laws concerning the use and ownership of this air weapon.

***** LIMITED LIABILITY WARRANTY *****

This product is warranted to the retail customer for 12 months from date of purchase against defects in materials and workmanship and is transferable to any subsequent owner.

Proof of purchase is required to receive warranty repairs, retain your purchase invoice and return the warranty registration card as soon as possible after purchase. The warranty card must show the dealer/supplier name and address and date of purchase.

WHAT IS COVERED

Replacement parts & labour on a 'back to base' basis, return transportation to the consumer (mainland uk only).

WHAT IS NOT COVERED

Transportation from to consumer to air arms.

Damage caused by misuse, abuse, lack of routine maintenance, transit damage between the dealer/supplier and the consumer or unauthorised disassembly.

Parts subject to normal wear and tear.

Any other consequential cost incurred by the consumer.

Return transportation to consumers outside mainland uk.

No warranty is implied as to the fitness for any particular purpose.

Do **not** store this rifle in a damp place such as garden shed or garage.

Do **not** store this rifle in a plastic or pvc gun bag without first applying a surface corrosion inhibitor.

Never leave this rifle in a cocked condition.

Always ensure the cocking lever is fully closed before firing.

Do not test fire the rifle without a pellet in the barrel. Air arms reserve the right to alter the construction, appearance or performance of any product without prior notification. All illustrations are for information purposes only and do not necessarily show the exact model that was purchased.

GENERAL MAINTENANCE

Regularly check the tightness of all fixings. Do not over-tighten, some parts are made from aluminium, stripped threads will result from over-tightening. Periodically clean the

Barrel with a good cleaner and pull through.

GENERAL LUBRICATION

Only use mineral based oils and never use silicone based oils on moving parts.

Regularly apply a few drops of gun oil the following wear points:

Link rod, link rod end & cocking lever pivots, compression tube.

It is essential to wipe over the external surfaces of the rifle with a soft oily rag to maintain the high surface finish. Failure to do this will result in surface corrosion.

Regular internal lubrication is not necessary. A small amount of grease is applied on assembly. Re-lubrication will be un-necessary for a considerable time. If the operation of the rifle becomes rough, stiff or noisy this could be an indication that lubrication is required and should be investigated.

FELT OR SIMILAR CLEANING PADS MUST NOT BE FIRED FROM THIS RIFLE UNLESS A PELLET IS INSERTED BEHIND THE PAD. ALTERNATIVELY, CLEAN THE BARREL WITH A PULL THROUGH.

DO NOT FIRE THIS RIFLE WITHOUT A PELLET IN THE BARREL AND ONLY USE LEAD PELLETS.

General lubrication (cont)

Do not apply lubricant to the barrel seals or allow lubricant to penetrate to the piston seal as dieseling may result. Dieseling is caused by oil or grease igniting when it is compressed in the compression tube when the rifle is fired. This process is very damaging to the seals and should be avoided at all costs.

A couple of drops of oil should be applied to the safety catch regularly to ensure safe operation. Preferably just before a shooting session.

Operating instructions.

1) To cock the rifle hold securely in one hand and with the other pull the cocking lever downwards (fig 1) until the trigger mechanism engages and the safety catch button pops out. The button has an indication groove, coloured RED, to show when it is correctly engaged. Be sure that you do not obstruct the safety button and prevent it from working during the cocking process. If you hold the rifle by the pistol grip whilst cocking, ensure that your finger is not on the trigger (fig 2) or you may accidentally cause the rifle to fire during the loading sequence.



Fig. 1



Fig. 2.

2) The cocking action opens the breech and exposes the barrel ready to insert a pellet (fig 3). **Always check the safety button before inserting a pellet.** In the interest of safety always keep a hold of the cocking arm whilst inserting a pellet.

3) After inserting a pellet, close the lever fully. Serious damage may result if the rifle is fired with the lever partly open.

4) Release the safety catch by pushing the button in fully, fig 4. The rifle is now ready to fire. The safety catch cannot now be re-engaged without re-cocking the rifle so it is best not to release the safety catch before you are ready to fire. Once cocked the rifle cannot be easily de-cocked, never fire the rifle without a pellet as this may damage the seals. If you have loaded and cannot fire at your chosen target but wish to make the rifle safe, fire the pellet into soft ground.



Fig. 3.



Fig. 4.

Trigger adjustment.

The trigger is a two stage unit with adjustments on both stages. Be aware that adjustment to one screw will affect the adjustments on the other and the trigger will only work properly if there is the correct balance between the two. If you have no experience in adjusting a two stage trigger, seek guidance or leave the trigger as set by the factory. Incorrect adjustment can make the rifle unsafe.

There are three adjustment screws. The weight of pull screw (A) which is located under the trigger guard which has to be removed to gain access. Turning this screw clockwise will increase the weight on the trigger. The other adjustment screws are in the trigger blade. The rear screw (B) adjusts the exact pull off point, the front screw (C) adjusts the length of first stage travel.

Remember that small adjustments will make noticeable changes to the operation of the trigger.

Important notice.

When the trigger guard is replaced the rear screw (TX460) must be tightened before the front screw (TX 440). Do not overtighten the front screw. This screw pulls the action into the stock and only needs to be tight enough to stop movement within the stock.

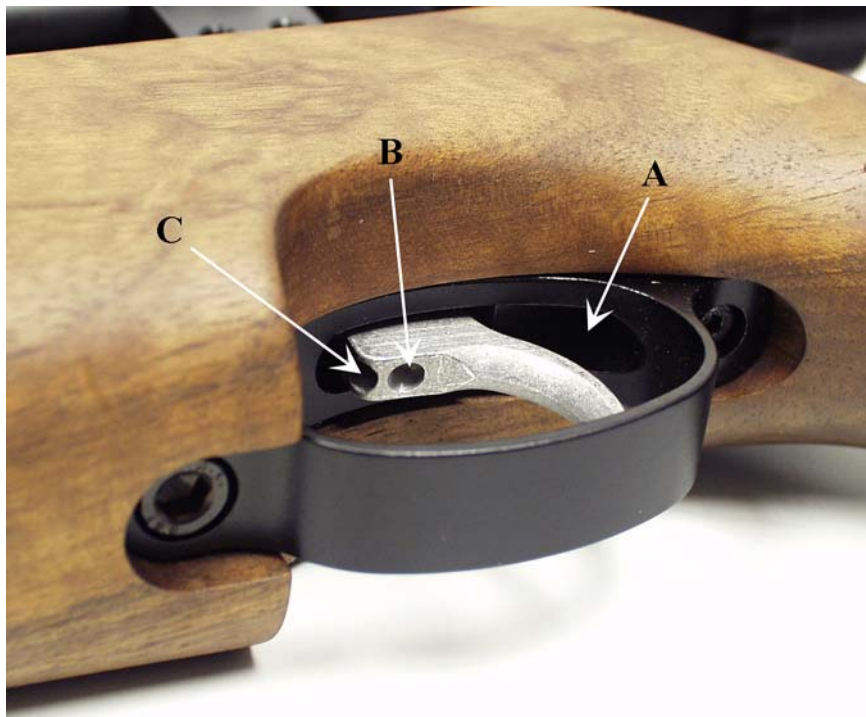

Have the rifle serviced by air arms or a competent gunsmith at least once a year.

Pro-Sport Parts List

Part No.	Description	Qty.	Part No.	Description	Qty.
PS215	Cylinder Assembly	1	PS418	Cocking Lever Stop Screw	1
PS240	Secondary Safety Button	1	PS425	Pivot Block	1
PS245	Cocking Lever Pin (small)	1	PS445	Beech Stock	1
PS246	Cocking Lever Pin (large)	1	PS450	Walnut Stock	1
PS250	Secondary Safety Pusher	1	S455	Cocking Block Screw	1
PS264H	Cocking Lever	1	TX221	Barrel Seal	2
PS280	Compression Tube Assembly	1	TX222	Barrel Retaining Nut	1
PS285	Cocking Block	1	TX305	Circlip	2
PS290H	Link Rod	1	TX320HH	Piston	1
PS293	Secondary Safety Spring	1	TX325	Front Piston Bearing	1
PS294H	Secondary Safety Block	1	TX330	Piston Seal	1
PS295	Link Rod End	1	TX340	Rear Piston Bearing	2
PS296	Link Rod Spring	1	TX350H	Fac Front Guide	1
PS298	Secondary Safety Block Spring	1	TX351H	Fac Mainspring	1
PS300	Front Link Rod Pin	1	TX352	.22 Front Guide	1
PS301	Rear Link Rod Pin	1	TX353	.177 Front guide	1
PS380	Trigger Block Assy Ex Unit	1	TX355	Mainspring	1
PS400	Barrel Assy 5.5mm (.22)	1	TX360H	Fac Rear Guide	1
PS401	Barrel Assy 4.5mm (.177)	1	TX362	Rear Guide	1
PS410	Trigger Block Retaining Bolt	1	TX420	Trigger Guard	1
PS415	Bottom Rail	1	TX435	Front Stock Screw	4
PS416	Cocking Lever Stop	1	TX440	Rear Stock Screw	1
PS417	Cocking Lever Buffer	1	TX460	Trigger Guard Fixing Screw	1

PLEASE QUOTE THE RIFLE & PART NUMBER IN ANY CORRESPONDENCE. SOME PARTS ILLUSTRATED ARE ONLY AVAILABLE AS FACTORY FITTED ITEMS ONLY THE PARTS THAT ARE ON THE PARTS LIST ARE AVAILBLE FOR DIY FITTING.

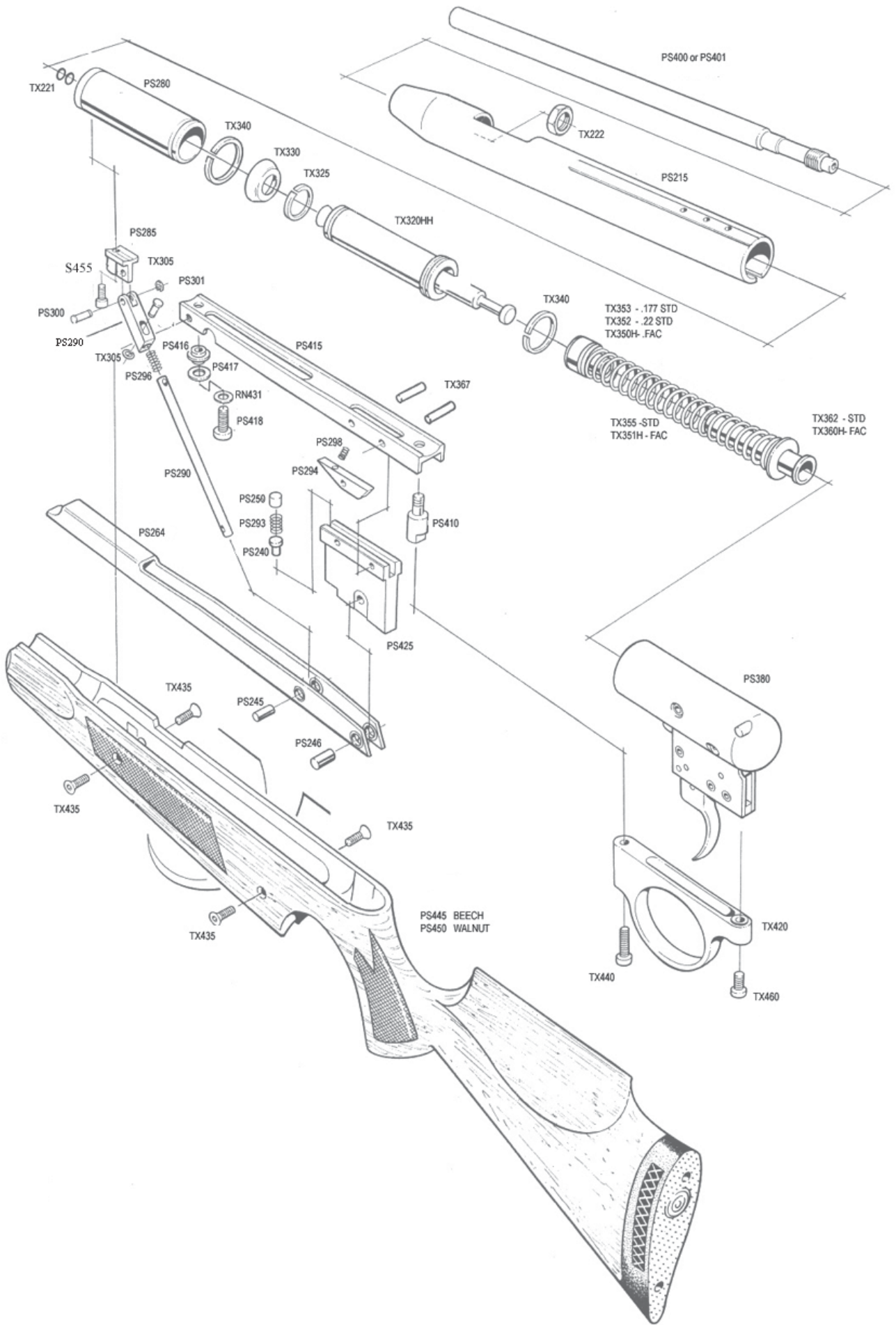

Trigger unit Parts List

Part No.	Description.	Qty.	Part No.	Description.	Qty.
TX365	Trigger Block	1	TX398	Trigger Chassis Pin	4
TX367	Trg/Blk & Piv/Blk Ret Pin	1	TX405	Trigger Chassis Bush	2
TX366	Trigger Block Retaining Pin	1	TX400	Bottom Sear	1
TX370	Safety Button	1	TX390	Top Sear	1
TX371	Safety Button Spring	1	TX395	Middle Sear	1
TX381	Trigger Adjusting Screw	1	TX431	Trigger Adjusting Screw	2
TX382	Trigger Adjusting Spring	1	PS430	Trigger Blade	1
TX396	Sear Spring	1	Tx432	Adjusting Screw Locking Pad	1
TX397	Sear Spring Retaining Pin	2			

PLEASE QUOTE THE RIFLE & PART NUMBER IN ANY CORRESPONDENCE. SOME PARTS ILLUSTRATED ARE ONLY AVAILABLE AS FACTORY FITTED ITEMS ONLY THE PARTS THAT ARE ON THE PARTS LIST ARE AVAILBLE FOR DIY FITTING

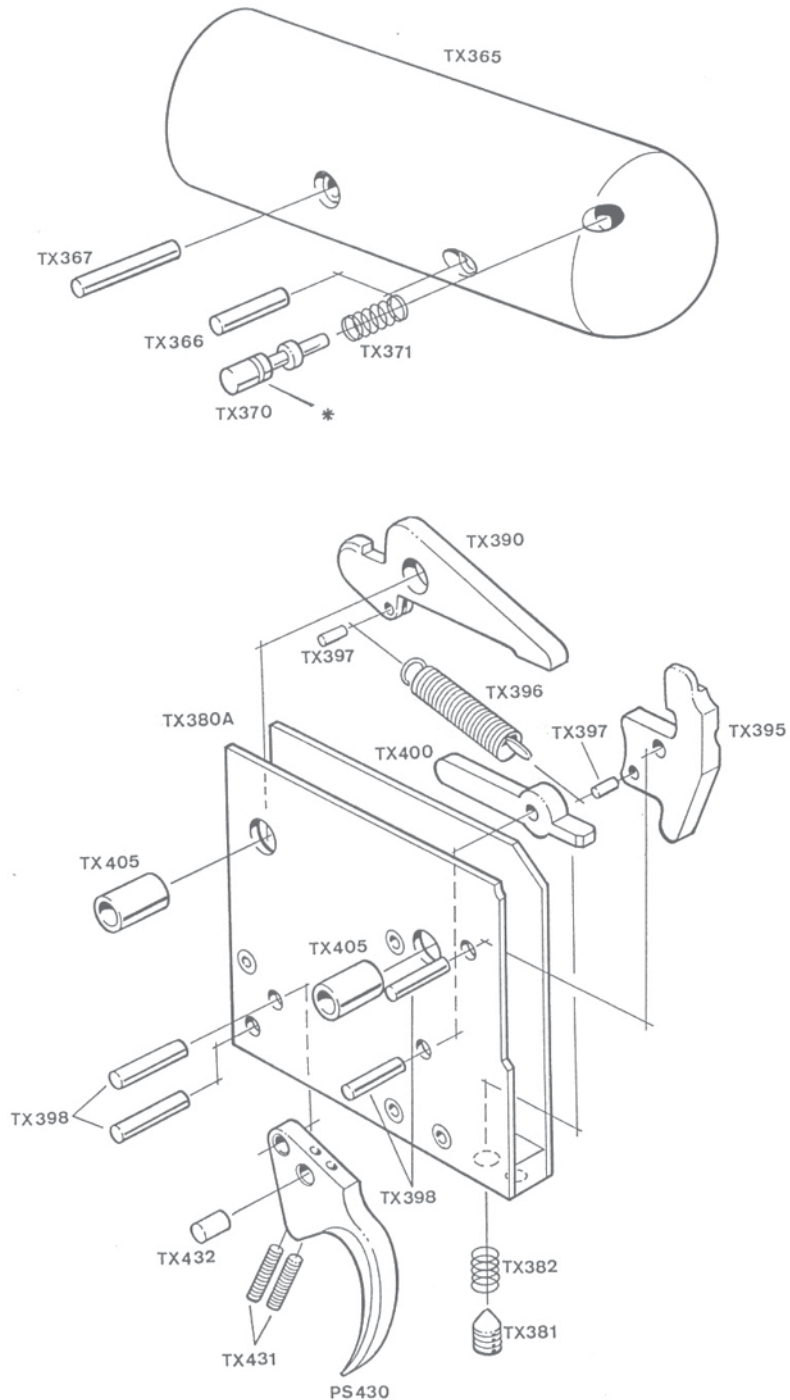

Air Arms, Unit 6, Hailsham Industrial Park, Diplocks
Way, Hailsham, East Sussex, England BN27 3JF.

Tel: 01323 845853. Fax: 01323 440573.

Website: www.air-arms.co.uk

Email: general@air-arms.co.uk

Notes.