

# RN10 MK11

## COMPRESSED AIR SYSTEM

PLEASE READ THIS INSTRUCTION BOOK BEFORE USING YOUR RN10 MK11

### GENERAL INFORMATION

LENGTH : 1200 M/M (1.2 MTRS)  
WEIGHT : 4.0 KGS  
MAX PRESSURE : 200 BAR  
MIN PRESSURE : 110 BAR  
SHOTS (at maximum pressure) :

ALWAYS TREAT YOUR RN10 MK11 AS IF LOADED. ALWAYS STORE/TRANSPORT WITH THE BREECH IN THE 'SPRING BACK' POSITION. REGULARLY SMEAR THE EXTERNAL SURFACES WITH OIL TO PREVENT SURFACE CORROSION. UNAUTHORISED DISASSEMBLY OR MODIFICATION WILL INVALIDATE THE WARRANTY.

USE COMPRESSED AIR ONLY. DO NOT USE ANY OTHER GAS OR GAS MIXTURE

### \*\*\*\* WARRANTY \*\*\*\*

THIS PRODUCT IS WARRANTED TO THE RETAIL CUSTOMER FOR 12 MONTHS FROM DATE OF PURCHASE AGAINST DEFECTS IN MATERIALS AND WORKMANSHIP. PROOF OF PURCHASE IS REQUIRED TO RECEIVE WARRANTY REPAIRS.

#### WHAT IS COVERED

REPLACEMENT PARTS AND LABOUR. RETURN TRANSPORTATION TO THE CONSUMER.

#### WHAT IS NOT COVERED

TRANSPORTATION FROM THE CONSUMER TO THE MANUFACTURER.  
DAMAGE CAUSED BY MISUSE, ABUSE, LACK OF MAINTENANCE OR DISASSEMBLY.  
ANY OTHER EXPENSES INCURRED BY THE CONSUMER.  
NO WARRANTY IS IMPLIED AS TO FITNESS FOR ANY PARTICULAR PURPOSE.

## IMPORTANT INFORMATION

### \*\*\*\* WARNING \*\*\*\*

- A ONLY COMPRESSOR WITH WATER FILTER UNIT MUST BE USED WHEN CHARGING RIFLES, OTHERWISE CORROSION AND MAL-FUNCTION WILL OCCUR WITH THE RIFLE.
- B RIFLES MUST BE REFILLED WHEN PRESSURE OF RIFLE IS DOWN TO 110 BAR. THIS WILL BE APPROXIMATELY AFTER 100 SHOTS HAVE BEEN FIRED FROM THE RIFLE.

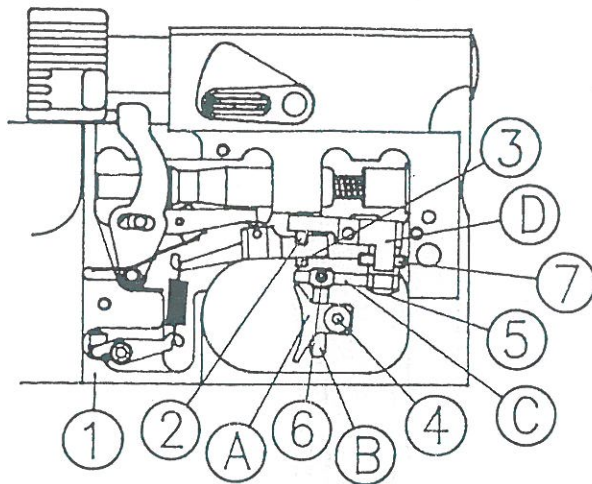

### TRIGGER ADJUSTMENT

- |                              |                            |
|------------------------------|----------------------------|
| (1) Trigger Weight Screw     | (7) Follow-On Travel Screw |
| (2) 1st Stage Travel Screw   | (A) Trigger Shoe           |
| (3) 2nd Stage Adjuster Screw | (B) Trigger Pillar         |
| (4) Trigger Shoe Screw       | (C) Trigger Bar            |
| (5) Trigger Bar Screw        | (D) Trigger Pivot Block    |
| (6) Trigger Pillar Screw     |                            |

The position of the Trigger Shoe can be moved in three planes as follows:

- (a) Vertically - By loosening screw (4) and sliding up/down on the Trigger Pillar (B).
- (b) Longitudinally - By loosening screw (6) and sliding Trigger Pillar (B) along Trigger Bar (C).
- (c) Radially - By loosening screw (5) and turning Trigger Bar (C) on the pivot block (D).

### TRIGGER WEIGHT ADJUSTMENT

The trigger weight is adjusted by turning screw (1) clockwise to increase weight and anticlockwise to decrease weight. Access to screw (1) is from underneath the stock, adjacent to the rear stock fixing screw.

### 1st STAGE TRAVEL ADJUSTMENT

1st Stage Travel is adjusted with screw (2). Turning the screw clockwise will decrease travel and anticlockwise increase travel.

### 2nd STAGE ADJUSTMENT

The 2nd stage is adjusted with screw (3). Turning the screw clockwise will increase the trigger travel between the end of 1st Stage and the 2nd stage. If the screw is turned too far anticlockwise, then the rifle will fire before the end of 1st Stage travel is reached.

### FOLLOW-ON TRAVEL ADJUSTMENT

Follow-On travel is adjusted with screw (7). Turn the screw clockwise to decrease or anticlockwise to increase the amount of trigger travel after the Let-Off point.

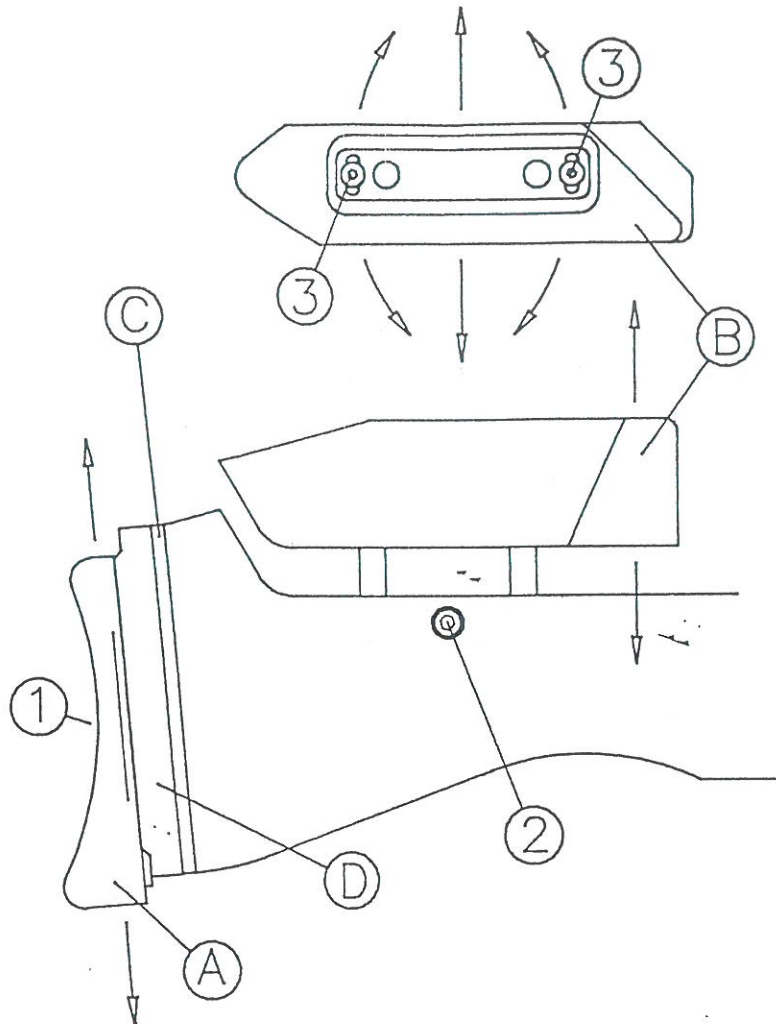

### STOCK ADJUSTMENTS

- |  |                         |
|--|-------------------------|
| (1) Shoulder Pad locking screw         | (A) Shoulder Pad        |
| (2) Cheek Piece vertical locking screw | (B) Cheek Piece         |
| (3) Cheek Piece lateral locking screws | (C) Shoulder Pad Spacer |
|  | (D) Mounting Block      |

- (a) The Shoulder Pad (A) can be adjusted vertically by first loosening screw (1).
- (b) The Cheek Piece (B) can be adjusted vertically by first loosening screw (2).
- (c) The Cheek Piece (B) can be adjusted laterally by first loosening screws (3).
- (d) The length of the stock can be reduced by removing spacer (C), or increased by fitting additional spacers. The spacers are 5mm thick and will require longer Mounting Block screws to suit the number of additional spacers.



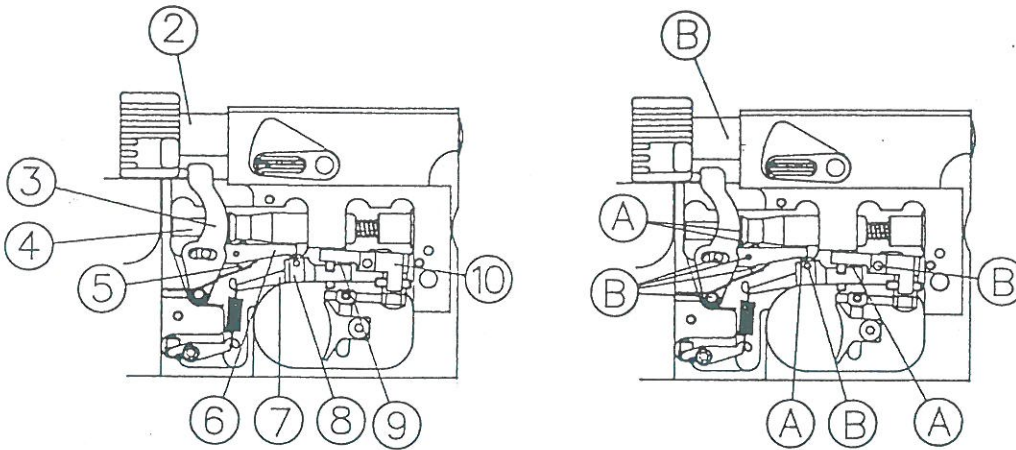

- (1) Breech Shaft
- (2) Cocking Arm
- (3) Piston
- (4) Piston Catch Plate
- (5) Top Sear

- (6) Middle Sear
- (7) Middle Sear Block
- (8) Trigger Cam Point
- (9) Pivot Block

**LUBRICATION**

The wear parts of the RN10 have been designed to require minimal lubrication during normal use. The lubricant applied to the internal parts during assembly at the factory is normally sufficient for 10000 shots, any roughness of operation may indicate that lubrication is necessary before this number.

If you have limited knowledge of the workings of a precision mechanism, maintenance and lubrication is best left to an experienced gunsmith or, preferably, the factory.

Regularly protect the external surfaces with a light smear of mineral oil.

Under or over lubrication will effect the consistency of the RN10.

Points (A), lubricate with Moly Grease

Points (B), lubricate with a low viscosity mineral oil.

**POINTS (A)**

- (a) Cocking Arm/Piston contact point
- (b) Top Sear/Middle Sear contact point
- (c) Trigger Cam Point
- (d) Piston/Piston Catch Plate contact point

**POINTS (B)**

- (e) Breech Shaft
- (f) Top Sear pivot pin
- (g) Cocking Arm pivot pin
- (h) Striker Catch Plate & pivot pin
- (i) Pivot Block pivot pin

Occasionally grease the connecting thread and 'O' ring between the cylinder and rifle with 'O' ring grease.

- \* DO NOT USE ANY OIL OR GREASE THAT CONTAINS SILICON \*
- \* DO NOT USE ANY SYNTHETIC OIL \*
- \* DO NOT LUBRICATE THE PISTON BEARINGS\*

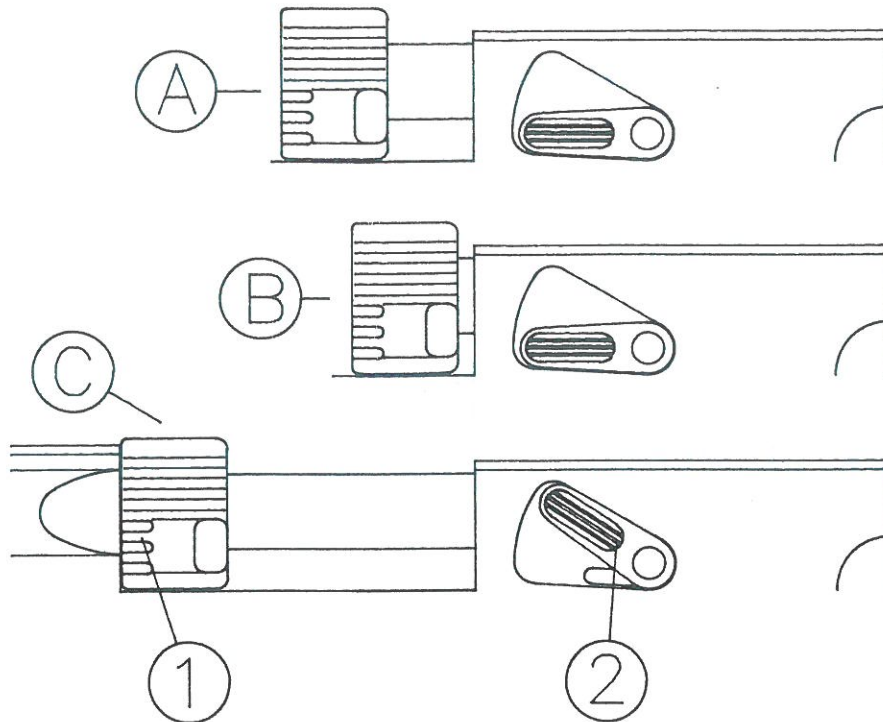

COCKING AND LOADING

- |  |                                     |
|--|-------------------------------------|
| (1) Breech Block                         | (B) Breech Block in Cocked Position |
| (2) Release Lever                        | (C) Breech Block in Firing Position |
| (A) Breech Block in Spring-Back Position |                                     |

The RN10 should always be stored and/or transported with the Breech Block (1) in the Spring-Back Position (A).

LOADING SEQUENCE

- (a) With the Breech Block (1) in position (A), pull the Breech Block (1) back until in position (B).
- (b) Insert pellet into barrel.
- (c) Push the Breech Block (1) forward until the Release Lever (2) clicks into the fully up position as in (C). (If the Release Lever is not in the fully up position, a misfire may result. This action is not dangerous, but will almost certainly mean a loss of a shot.)
- (d) The RN10 is now ready to fire.
- (e) Immediately after firing, push Release Lever (2) down until the Breech Block (1) springs back to position (A).

It is quite safe to cock and test fire the RN10 without loading a pellet into the barrel.

