

AIR ARMS

World Class Air Rifles

USERS HANDBOOK

THIS HANDBOOK REFERS TO S200 ACF MODEL RIFLE



***** SAFETY CODE *****

- 1 - TREAT THIS AIR RIFLE AS IF LOADED.
- 2 - NEVER POINT IT AT ANYONE, EVEN IF UNLOADED.
- 3 - NEVER LEAVE THIS RIFLE UNATTENDED WHEN COCKED OR LOADED.
- 4 - ALWAYS BE SURE OF WHAT LIES BEYOND YOUR TARGET.
- 5 - ALWAYS CONDUCT YOURSELF IN A SPORTSMAN-LIKE MANNER.

ALWAYS BE AWARE THAT YOUR ACTIONS WILL BE UNDER THE SCRUTINY OF OTHER MEMBERS OF THE PUBLIC WHO MAY NOT SHARE YOUR ENTHUSIASM FOR AIR WEAPONS. BAD PRACTICES PROMOTE BAD PUBLICITY. DO NOT JEOPARDISE YOUR FUTURE ENJOYMENT BY MISUSING THIS WEAPON.



Certificate of Conformity

Product: **Air Rifle**

Product Series: **Air Arms S200 Cadet**

Model Number: **S205T17SX06ACO, S210T17SX06ACO,
S207SSRB6**

Manufacturer: **Ceska Zbrojovka A.S.**

We hereby certify that the above product complies with the following relevant statutory requirements:-

Firearms Act 1968

Simple Pressure Vessels Directive 87/404/EEC

Simple Pressure Vessels (Safety) Regulations 1991

Simple Pressure Vessels (Safety) (Amendment) Regulations 1994.

Pressure Equipment Directive 97/23/EC

Pressure Systems Safety Regulations 2000

Signature

A handwritten signature in black ink, appearing to read 'CW', is written over a faint, illegible stamp.

Claire West / Managing Director

Date: 1st May 2012

Air Arms, Units 5 & 6, Hailsham Industrial Park, Diplocks Way , Hailsham,
East Sussex, England, BN27 3JF

PLEASE READ THIS MANUAL BEFORE USING YOUR NEW RIFLE, IT CONTAINS IMPORTANT SAFETY INFORMATION AND INSTRUCTION ON ADJUSTMENT AND MAINTENANCE.

Important information

Before leaving the factory this rifle was Q.A. inspected and test fired using Air Arms pellets to check operation and final adjustment.

It was dispatched in a sealed purpose designed box with a contents label on the lid. Air Arms may not be responsible for any damage to the contents or missing items if the box is not original, if it is damaged or the seals are not intact.

Air Arms cannot be held responsible for damage or missing items due to transit damage, mishandling or being tampered with after leaving the factory.

If this rifle is not received in the original box with the seals intact, please examine carefully for any damage, missing tools or documentation.

In the first instance any problems or complaints regarding this product should be referred to the supplier. The air cylinder is a highly pressurised unit that must not be modified in any way. Serious personal injury may result if this, and the advice below is not followed.

Do not pressurize the cylinder if there are any surface abrasions or dents. Contact Air Arms for advice.

Do not store the rifle in places with, or near sources of high temperature such as fires or boilers.

Do not attempt to dismantle when pressurised.

Do not pressurize beyond the stated filling pressure (see filling instruction section). Damage caused by such action is not covered by the manufacturer's warranty.

Only use clean, filtered and dry compressed air. Never use any other gas, particularly industrial or welding gases such as oxygen, carbon dioxide, acetylene, hydrogen, argon, etc.

If compressed air is being used other than from a diving shop, the inside of the cylinder should be inspected for corrosion at least annually. If in doubt contact Air Arms for advice.

The cylinder should be inspected every two to three years depending upon usage.

Air Arms can provide this service at a reasonable cost.

To maintain this rifle in good working order it should be serviced annually by a competent gunsmith. Your supplier may be able to provide this service or contact Air Arms.

A reasonable amount of advice will be provided to enable the end user to service their own rifle, however this is at the discretion of Air Arms and may not be given in all cases.

The velocity of this rifle has been set using Air Arms field pellets. If any other make or type of pellet is to be used the rifle must be re-tested with the pellet that is to be used, to ensure the muzzle energy is within the limits determined by current legislation.

Due to the nature of hand pumps and their relative inefficiency in removing moisture from the compressed air, the chances of corrosion damage to the cylinder and other internal components are increased therefore the rifle should be regularly serviced and/or checked for any signs of damage by a competent gunsmith.

Air Arms recommend using a dry pack filter kit on any hand pumps used to fill our air rifles.

If accessories not manufactured by Air Arms are used on this rifle, Air Arms can not be held responsible for any loss of performance. Contact your supplier or Air Arms for any advice on this matter.

Do not store this rifle in a damp place such as garden shed or garage.

Do not store this rifle in a plastic or PVC gun bag without first applying a surface corrosion inhibitor.

Always ensure the loading bolt is fully closed before firing.

FILLING INSTRUCTIONS

NOTE! ONLY USE CLEAN, DRY AND FILTERED COMPRESSED AIR. OVER PRESSURIZATION MAY DAMAGE THE CYLINDER BEYOND REPAIR.

First the female part of the filling kit (this was supplied with the rifle) must be fitted to your filling equipment. The female part (S475) has a 1/8th BSP male thread that screws directly into the hose of your pump.

Next remove the dust cover from the end of your rifle. This is achieved by unscrewing the cover in an anti-clockwise direction.

Once the connector is exposed the female part of the filling kit can be placed on the male and pushed all the way on, making sure that the 'O' rings on the male part are covered. When the two parts are fully located the Tee piece on the male connector will push through the slot on the female. The female can now be turned to engage the tee piece and lock the two items together.

With the female in place the gun can now be filled.

If the rifle is empty the mechanism will need to be cocked to allow the firing valve to close. If the

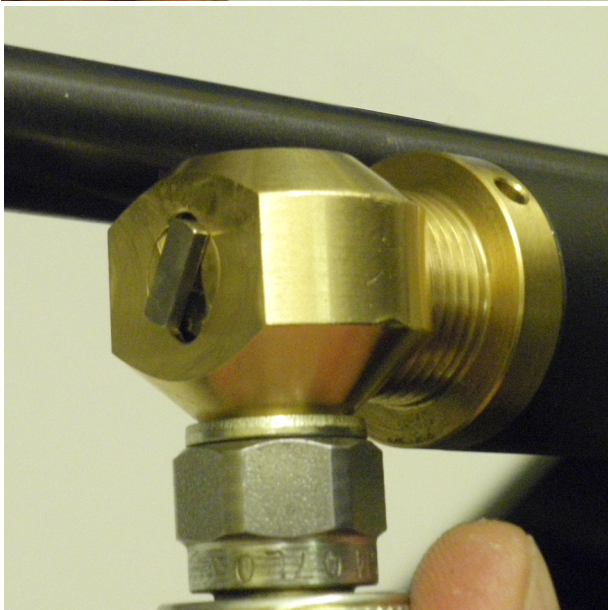

rifle is not cocked when the pump is used, the air will pass the valve and exhaust through the barrel.

Check that the bleed valve on the filling equipment is closed (turn clockwise to close) then start using the pump. The pressure in the hose will equalise and then the rifle will start to fill.

If you are filling your rifle from empty there may be some air exhausted through the barrel until the air pressure is sufficient to overcome the firing valve spring. This will happen at approximately 50 bar (750psi).

The filling pressure of the S200 is 200 bar (2900psi), filling to a higher pressure will not increase either power or number of shots. Over filling will lower the power and may cause irreparable damage to the cylinder.

Once the filling pressure has been reached, stop pumping, open the bleed valve on the filling kit to vent the hose (if you do not vent the hose you will not be able to remove the female from the rifle). Now the female connector can be removed from the rifle and the end cap can be refitted over the male connector ensuring not to overtighten.



Note on hand pumps: It is important to turn the female on the gun to lock it in place as the action of pumping may move the hose around.

When using the pump it must be remembered that the first few pumps are filling the hose and NOT the gun. When the pressure in the hose equalizes to that in the gun, the gun will start to fill. It can take some effort to fill the gun using a pump and we recommend using the pump to top up instead of filling from empty.

OPERATING INSTRUCTIONS

Cocking the rifle

To cock the rifle lift the handle up and pull the rear of the action in a smooth motion. The breech will open and the trigger mechanism will be engaged. Now close the breech by pushing the bolt forward and locking the handle back in the down position. From this point on the rifle will fire.



Loading the rifle

The S200 can be used as a single shot rifle with the pellet tray fitted and also a multi shot rifle with the 5 or 10 shot magazine system fitted.

If you are using the pellet tray, when the bolt is in the rear position during the cocking cycle, place a pellet in the tray. When the bolt is closed it will push the pellet forward and into the breech ready to fire.



If you are using a magazine system you will need to load the pellets into the pellet carrier.

With the bolt in the rear position, slide the pellet carrier from the housing. Insert the pellets directly into the carrier and push them home until the O ring holds them in place.

Once all the pellets have been inserted, line up the keyway on the back of the carrier with the notch on the housing and slide the carrier back into the mechanism. Push the loading bolt forward and lock it down. You are ready to fire now.

When cocking the rifle from now on, the pellet carrier will automatically rotate and present a new pellet.



Note on 5 & 10 shot magazines

The pellet carrier of the magazine system has a key way slot cut into the back (see arrows). This slot must line up with the key on the inside of the housing. On the 5 shot there are two slots and on the 10 shot magazine there is one slot. When using the 5 shot magazine the pellet carrier must be loaded into the housing as shown, pellet side first.

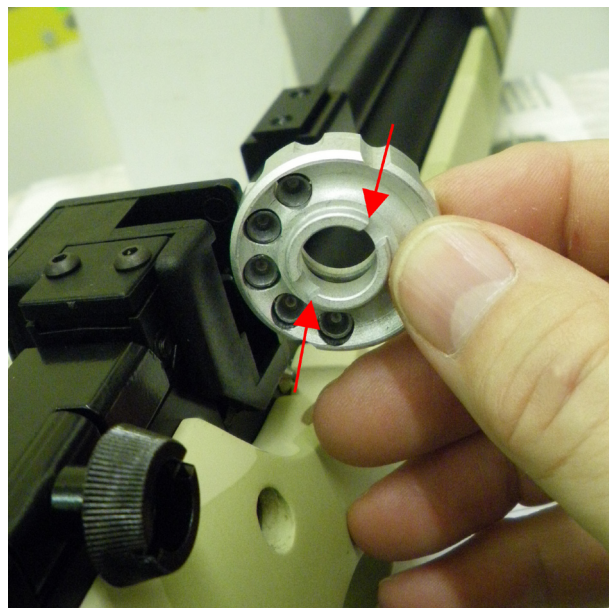

Note: To ensure the continued smooth operation of your magazine system, the pellet retaining O ring in the magazine needs to be regularly lubricated with a thin oil such as 3-in-1 to prevent premature wear and/or damage.

MAINTENANCE

FIXINGS

Regularly check the tightness of all fixings. However do not be tempted to over tighten as some parts are made from aluminium and stripped threads may result. Stripped threads are not covered by the manufacturers warranty.

BARREL

For ultimate accuracy, clean and re-lube the barrel frequently. It is difficult to advise how often is best for every circumstance, but every 250 shots is not too often if the desire is to keep the barrel in the best possible condition.

The correct materials are very important. Air Arms only use products made by Napier. Listed below is the Napier product and a more generally available alternative. If possible use Napier for the best results.

CLEANER:	‘NAPIER GUN CLEANER’, ALTERNATIVELY WHITE SPIRIT.
OIL:	‘NAPIER GUN OIL’, ALTERNATIVELY ‘3 IN 1’ OIL.
PULL-THROUGH PAD:	‘NAPIER RIFLE CLEAN’, ALTERNATIVELY SOFT COTTON CLOTH.
PULL-THROUGH LINE:	‘NAPIER PULL THROUGH KIT’, ALTERNATIVELY 20lb FISHING LINE

As a rule cleaners and oils intended for shotguns and small/full-bore weapons are not suitable.

1. Cut a piece of line three times the length of your barrel, fold in half and tie ends together. Remove silencer if fitted. Open loading bolt.
2. Feed un-knotted end down barrel from the muzzle end until folded end protrudes out 50mm.
3. Cut a 100mm length of ‘rifle clean’ or 100 x 50mm piece of cloth and pass it between the protruding loop. Spray the pad with ‘gun cleaner’ or white spirit, turn the rifle upside down and pull the line back through the barrel slowly.
4. Repeat steps 2&3 until the pad is clean.
5. Repeat steps 2&3 once more without any cleaner on the pad to dry the barrel.
6. Repeat steps 2&3 once more with the pad sprayed with ‘gun oil’ or 3 in 1 oil.

IMPORTANT : THE REASON FOR TURNING THE RIFLE UPSIDE DOWN IS TO PREVENT EXCESS CLEANER/OIL FROM PASSING DOWN THE TRANSFER PORT INTO THE FIRING VALVE CHAMBER.

LUBRICATION

Lubrication of the internal mechanism is not covered in this handbook. This is best performed by Air Arms or a competent gunsmith and in any case should not be required until the annual service.

With proper care your Air Arms air rifle will give you many years of fine reliable service.

Remember

*Always treat your rifle as if it is loaded.
Never point your rifle at anyone even if unloaded or not cocked.
Always be sure of what lies beyond your target.
Always conduct yourself in a sportsman like manner.*

Treat all airguns with care. They are not toys and can severely injure you or others and cause damage to property. Always be aware that your actions will be under the scrutiny of other members of the public who may not share your enthusiasm for air guns.

Bad practises promote bad publicity. Do not jeopardise your future enjoyment by misusing this gun.

Warning. Pre-Compressed Pneumatic (PCP) air guns work under very high pressure and must NOT be tampered with in any way.

Air Arms reserve the right to alter the construction, appearance or performance of any product without prior notification. All illustrations are for information only and do not necessarily show the exact model that was purchased.

Parts not listed in the diagrams

Magazines

S217A-5R	-	.177 (4.5mm) 5 magazine system
S217A-10R	-	.177 (4.5mm) 10 magazine system
S222A	-	.22 (5.5mm) 10 magazine system
S217C-5	-	.177 (4.5mm) 5 shot pellet carrier
S217C	-	.177 (4.5mm) 10 shot pellet carrier
S222A	-	.22 (5.5mm) 10 shot pellet carrier

Stock & Stock Screws

CZ110STOCK	-	Beech stock
CZ110CAMO	-	Camouflage coated stock
CZ115	-	Fore end stock front screw
CZ120	-	Fore end stock rear screw
CZ047	-	Fore end stock screw washer
CZ072	-	Side stock screw
CZ073	-	Side stock screw washer

Miscellaneous

S475	-	Filling adaptor
CZ094	-	Stock removal tool
S240A	-	Magazine lock
6213147F	-	Front sight
6213147R	-	Read sight
S201	-	Element set

Exploded parts list and diagrams for model No: S2077SSRB6.

This list does not include stock and screws, sights and element set or magazine system and pellets carriers.

Item No	Part No	Description	Qty	Item No	Part No	Description	Qty	Item No	Part No	Description	Qty
1	S211	Muzzle end	1	32	CZ032	Cylinder	1	63	CZ063	Trigger lever	1
2	S228	Muzzle end screw	1	33	CZ033	Pot	1	64	CZ064	Distance washer	2
3	CZ003-1	Barrel - .177 (4.5mm)	1	34	CZ034	Valve cap	1	65	CZ065	Sear pin	2
4	CZ004	Sight base	1	35	CZ035	Valve spring	1	66	CZ066	Trigger base	1
5	RN113	M5 x 6 screw	4	36	CZ036	Firing valve seal	1	67	CZ067	M3 x 6 screw	2
6	CZ006	Pellet channel screw	2	37	CZ037	Firing valve gate	1	68	CZ068	Base spring	1
7	CZ007	Pellet cahnnel - .177 (4.5mm)	1	38	CZ038	Firing valve end plug	1	69	CZ069	Locking washer	1
8	RN191	Transfer port screw	1	39	CZ039	Cylinder to body seal	1	70	CZ070	Front adj screw	2
10	CZ010	Ball catch body	1	40	CZ040	Striking pin	1	71	CZ071	Trigger blade	1
11	CZ011	Ball catch spring	1	41	CZ041	Striking pin spring	1	75	CZ075	M6 washer	1
12	CZ012	M3 ball bearing	1	42	CZ042	Circlip	1	76	CZ076	Connecting screw	1
13	CZ013	Breech body - .177 (4.5mm)	1	43	CZ043	Cylinder support	1	80	S319	Valve spring	1
14	CZ014	Loading bolt O ring	1	49	CZ049	Cocking arm guide	1	81	S473	Filling valve	1
15	CZ015-2/3	Loading bolt - .177 (4.5mm)	1	50	CZ050	Cocking arm guide screw	2	82	S327	Filling valve seal	1
16	TX228	M4 x 4 screw	2	51	CZ051	Cocking arm	1	83	S471	Filter	1
17	CZ017	Roller bush - large loading bolt	1	52	CZ052	Cocking arm pivot	1	84	S484	Male connector to plug seal	1
18	CZ018	Laoding bolt screw	2	53	CZ053	Nut socket	1	85	CZ085-2	End plug	1
19	CZ019	Nut	1	54	CZ054	Cocking arm spring	1	86	CZ086	Connector cover	1
20	CZ023-3	Loading bolt handle	1	55	CZ055	Cocking arm spring pin	1	87	S472	Male connector	1
22	CZ022	Mainspring adjuster	1	56	CZ056	Stock screw fastening	1	88	S474	Male connector O ring	2
23	CZ023/2	Mainspring 7.5j	1	57	FP188	Washer	1	89	CZ089	Latching nut	1
24	CZ024	Mainspring guide	1	58	CZ058	Latch washer	1	92	CZ092	Trigger screw	1
25	CZ025	Striker	1	59	CZ059	M4 x 6 screw	2	95	CZ095	M4 half nut	1
26	CZ026	Roller bush - large striker	1	60	CZ060	Lever spring	1	96	S581	M5 x 5 screw	1
29	CZ029	Roller bush - small	2	61	CZ061	Trigger weight adj_screw	1				
31	CZ031	Cylinder O ring	2	62	CZ062	Trigger guard	1				

Parts List for the magazine system S217A-5R & S217A-10R.

ITEM NO.	PART NUMBER	DESCRIPTION	QTY.
1	S220	Magazine body	1
2	S217-5	Pellet carrier .177 (4.5mm) - 5 shot	1
	S217	pellet carrier .177 (4.5mm) - 10 shot	
3	S223	Clamp	1
4	S224	Clamp plate	1
5	S227	Lever	1
6	S230	Lever pivot pin	1
7	S221	Magazine cover	1
8	S225	Side spring	1
9	S218	12 x 3.5 O ring	1
10	S226	Side spring pin	2
11	S232	Roller	1
12	S581	M5 x 5 screw	1
13	RN351	M4 nut	1
14	RN102A	Clamp screw	1
15	S229	Clamp plate screw	2
16	S231	Lever spring	1
17	RN106	Magazine cover screw	2

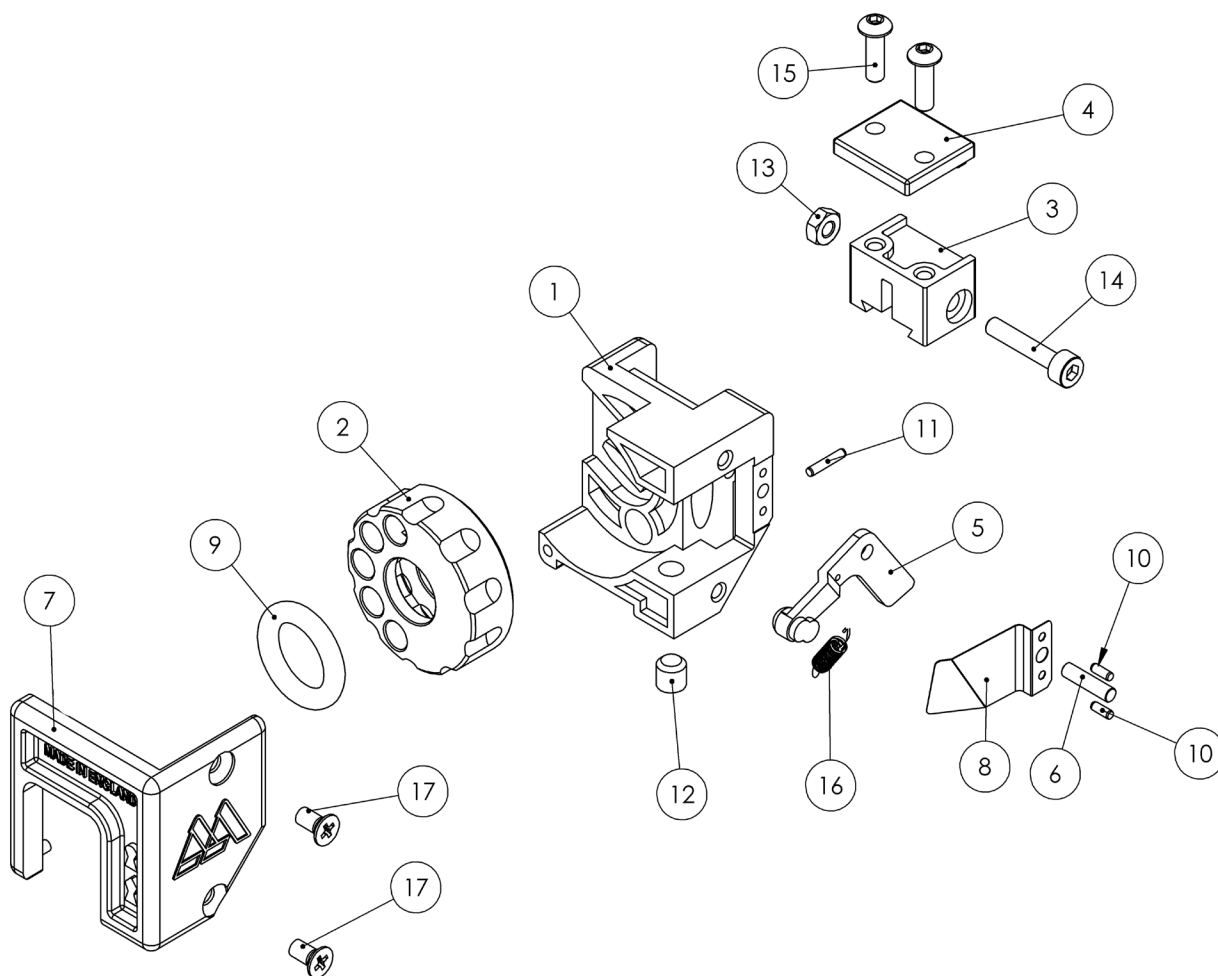

If you find that the magazine does not index correctly or the bolt will not go through, there is an adjustment screw on the left hand underside of the main body. This screw sets the position of the magazine and can be adjusted in (makes magazine rotate clockwise) or out (magazine will rotate anti-clockwise). The screw has 2.5mm head and if you do make any adjustments, it is a good idea to make a note of them so you can return to the start position.

Part List for the optional magazine brake system. S240A

ITEM NO.	PART NUMBER	DESCRIPTION	QTY.
1	S240	Magazine brake body	1
2	S245	Magazine brake probe	1
3	CZ012	M3 ball	1
4	JT228	Screw	1
5	RN102A	Clamp screw	1
6	S522	Spring	1

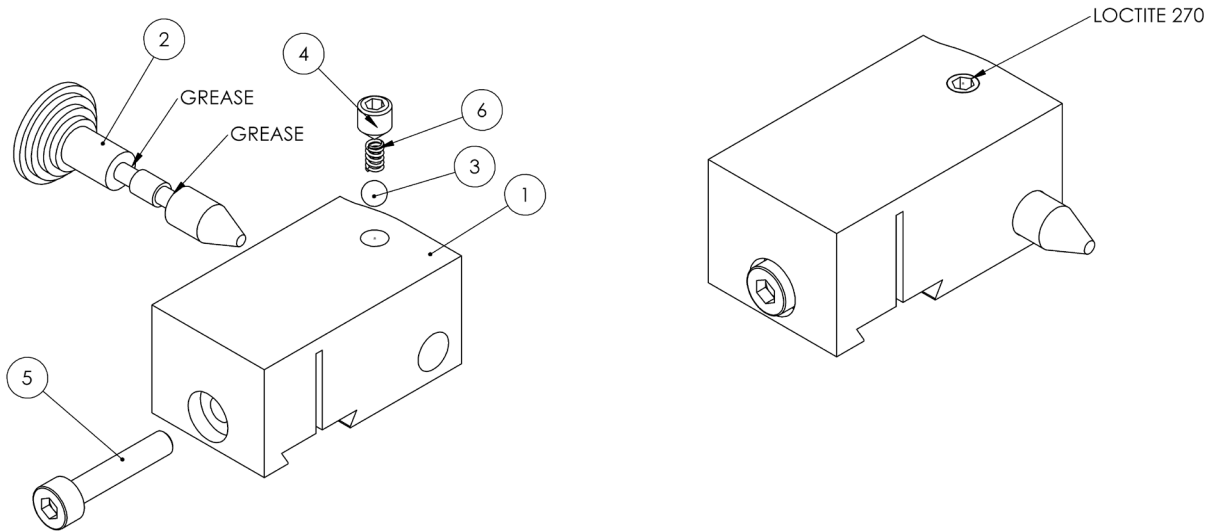

Gun security

It is important to make sure that your gun is always kept in a safe and secure fashion when not in use.

For rifles purchased in the UK and that are NOT FAC rated (high power) a free gun lock and mounting eyes are supplied. Please follow the simple fixing instructions and keep our sport safe.

Note: If there is no gun lock in the box please contact the dealer you purchased the rifle from.



WARRANTY (UK ONLY)

This product is warranted to the retail consumer for 12 months from date of purchase against defects in material and workmanship and is transferable. Proof of purchase is required to receive warranty repairs.

Retain your invoice and return the warranty form (below) or fill in the online form at; www.air-arms.co.uk/warranty-submission.

What is covered

Replacement parts and labour. Return transportation to the consumer (UK mainland only).

What is not covered

Transportation from the consumer to Air Arms.

Damage caused by misuse, abuse, disassembly or lack of routine maintenance.

No warranty is implied as to the fitness for any particular purpose. Return transportation to consumers outside the UK mainland.

PLEASE RETURN THIS PART

Gun No _____ Model _____

Date of Purchase _____

Purchased from _____

Your name and address _____

IMPORTANT INFORMATION

Please read the following information and instructions in the users handbook, they are vital to the long term serviceability of your rifle.

The adjustments and settings of this rifle have been set with special equipment at the factory to obtain the optimum performance, these must not be altered in any way (unless otherwise indicated in the users handbook).

If you experience any problems, contact your retailer and explain the fault, they will advise you on whether the rifle should be returned to them or Air Arms.

May we suggest the you have the rifle serviced annually to maintain the long term reliability of the rifle, it is important for us to keep a record of all users. Could we please ask you to complete the form overleaf and return to Air Arms.

This will enable us to contact you in future, to pass on useful information and/or to get your opinions and general feedback.

Anticipating your cooperation and wishing you every success in your shooting.

Affix
stamp
here

AIR ARMS
HAILSHAM INDUSTRIAL PARK
DIPLOCKS WAY
HAILSHAM
EAST SUSSEX BN27 3JF
ENGLAND

Air Arms, Unit 6, Hailsham Industrial Park, Diplocks
Way, Hailsham, East Sussex, England BN27 3JF.

Tel: 01323 845853. Fax: 01323 440573.

Website: www.air-arms.co.uk

Email: general@air-arms.co.uk