

MODEL
S410 CLASSIC &
CARBINE



USERS HANDBOOK

THIS HANDBOOK REFERS TO S410S CLASSIC & S410C CARBINE MODELS

PLEASE READ THIS MANUAL BEFORE USING YOUR NEW RIFLE, IT CONTAINS IMPORTANT SAFETY INFORMATION AND INSTRUCTION ON ADJUSTMENT AND MAINTENANCE.



Model shown with optional scope and moderator.

***** SAFETY CODE *****

- 1 - TREAT THIS AIR RIFLE AS IF LOADED.
- 2 - NEVER POINT IT AT ANYONE, EVEN IF UNLOADED.
- 3 - NEVER LEAVE THIS RIFLE UNATTENDED WHEN COCKED OR LOADED.
- 4 - ALWAYS BE SURE OF WHAT LIES BEYOND YOUR TARGET.
- 5 - ALWAYS CONDUCT YOURSELF IN A SPORTSMAN-LIKE MANNER.

ALWAYS BE AWARE THAT YOUR ACTIONS WILL BE UNDER THE SCRUTINY OF OTHER MEMBERS OF THE PUBLIC WHO MAY NOT SHARE YOUR ENTHUSIASM FOR AIR WEAPONS. BAD PRACTICES PROMOTE BAD PUBLICITY. DO NOT JEOPARDISE YOUR FUTURE ENJOYMENT BY MISUSING THIS WEAPON.

WARNING ! - UNAUTHORISED DISASSEMBLY OF THIS RIFLE WILL INVALIDATE THE MANUFACTURERS WARRANTY

Contents of Box.

1	x	S410 Rifle.	
1	x	Toll kit consisting of:	1 x 1.5mm allen key 1 x 2.5mm allen key 1 x female filling adaptor.
1	x	Manual.	

IMPORTANT INFORMATION, PLEASE READ

Before leaving the factory this rifle was Q.A. inspected and test fired using Air Arms PELLETS to check operation and final adjustment.

It was dispatched in a sealed purpose designed box with a contents label on the lid. Air Arms may not be responsible for any damage to the contents or missing items if the box is not original, if it is damaged or the seals are not intact.

Air Arms cannot be held responsible for damage or missing items due to transit damage, mis-handling or being tampered with after leaving the factory.

If this rifle is not received in the original box with the seals intact, please examine carefully for any damage, missing tools or documentation.

In the first instance any problems or complaints regarding this product should be referred to the supplier.

The air cylinder is a highly pressurised unit that must **not** be modified in any way. Serious personal injury may result if this, and the advice below is not followed.

Do **not** pressurise the cylinder if there are any surface abrasions or dents. Contact Air Arms for advice.

Do **not** store the rifle in places with, or near sources of high temperature such as fires or boilers.

Do **not** attempt to dismantle when pressurised.

Do **not** pressurise beyond the stated filling pressure (see filling instruction section). Damage caused by such action is **not** covered by the manufacturers warranty.

Only use clean, filtered and dry compressed air. **Never** use any other gas, particularly industrial or welding gases such as oxygen, carbon dioxide, acetylene, hydrogen, argon, etc.

If compressed air is being used other than from a diving shop, the inside of the cylinder should be inspected for corrosion at least annually. If in doubt contact Air Arms for advice.

In any event the cylinder should be inspected every two to three years depending upon usage. Air Arms can provide this service at a reasonable cost.

To maintain this rifle in good working order it should be serviced annually by a competent gunsmith, your supplier may be able to provide this service or contact air arms.

A reasonable amount of advice will be provided to enable the end user to service their own rifle, however this is at the discretion of Air Arms and may not be given in all cases.

The velocity of this rifle has been set using Air Arms field pellets. If any other make or type of pellet is to be used the rifle must be re-tested with the pellet that is to be used, to ensure the muzzle energy is within the limits determined by current legislation.

Due to the nature of hand pumps and their relative inefficiency in removing moisture from the compressed air, the chances of corrosion damage to the cylinder and other internal components are increased. Therefore the rifle should be regularly serviced and/or checked for any signs of damage by a competent gunsmith.

Air Arms recommend using a dry pack filter kit on any hand pumps used to fill our air rifles.

If accessories **not** manufactured by Air Arms are used on this rifle, Air Arms can not be held responsible for any loss of performance.

Contact your supplier or Air Arms for any advice on this matter.

Important information continued.

CHECKING VELOCITY

- 1 Use a reliable chronograph to check velocity, (the formula below requires the reading to be in feet per second - FPS)
- 2 Use fine measurement scales to weigh the pellet, If scales are unavailable the pellet weight may be stated on the pellet container lid or contact the supplier. (The formula requires the weight to be in grains). To convert from grams to grains multiply by 15.432, i.e. 0.69 grams x 15.432 = 10.65 grains.
- 3 To find the muzzle energy in ft/lbs use the formula $(FPS \times FPS \times Grains) / 450240$, i.e. $(700 \times 700 \times 10.65) = 5218500$ divide by 450240 = 11.59.

CURRENT LEGISLATION LIMITS NON-FAC HOLDERS, IN THE UK, TO AIR RIFLES WITH A MAXIMUM OF 12ft/lbs MUZZLE ENERGY.

WARNING! IT IS A VERY SERIOUS OFFENCE TO BE IN POSSESSION OF AN AIR RIFLE THAT YOU ARE NOT CERTIFICATED FOR. CONVICTION CAN RESULT IN CONFISCATION OF YOUR RIFLE, A HEAVY FINE OR IMPRISONMENT, EVEN A COMBINATION OF ALL THREE.

Do **not** store this rifle in a damp place such as garden shed or garage.

Do **not** store this rifle in a plastic or PVC gun bag without first applying a surface corrosion inhibitor.

Always ensure the loading bolt is fully closed before firing.

***** LIMITED LIABILITY WARRANTY *****

UK Customers only.

This product is warranted to the retail customer for 12 months from date of purchase against defects in materials and workmanship and is transferable to any subsequent owner.

Proof of purchase is required to receive warranty repairs, retain your purchase invoice and return the warranty registration card as soon as possible after purchase. The warranty card must show the dealer/supplier name and address and date of purchase.

What is covered

Replacement parts & labour on a 'back to base' basis, return transportation to the consumer (mainland UK only).

What is not covered

Transportation from the consumer to Air Arms.

Damage caused by misuse, abuse, lack of routine maintenance, transit damage between the dealer/supplier and the consumer or unauthorised disassembly.

Parts subject to normal wear and tear.

Any other consequential cost incurred by the consumer.

Return transportation to consumers outside mainland uk.

No warranty is implied as to the fitness for any particular purpose.

AIR ARMS RESERVE THE RIGHT TO ALTER THE CONSTRUCTION, APPEARANCE OR PERFORMANCE OF ANY PRODUCT WITHOUT PRIOR NOTIFICATION. ALL ILLUSTRATIONS ARE FOR INFORMATION PURPOSES ONLY AND DO NOT NECESSARILY SHOW THE EXACT MODEL THAT WAS PURCHASED.

GENERAL MAINTENANCE AND LUBRICATION

MAINTENANCE

FIXINGS

Regularly check the tightness of all fixings. However do **not** be tempted to over tighten as some parts are made from aluminium and stripped threads may result. Stripped threads are not covered by the manufacturers warranty.

BARREL

For ultimate accuracy, clean and re-lube the barrel frequently. It is difficult to advise how often is best for every circumstance, but every 250 shots is not too often if the desire is to keep the barrel in the best possible condition.

The correct materials are very important. Air arms only uses products made by Napier. Listed below is the Napier product and a more generally available alternative. If possible use Napier for the best results.

<i>CLEANER :</i>	<i>'NAPIER GUN CLEANER', ALTERNATIVELY WHITE SPIRIT.</i>
<i>OIL :</i>	<i>'NAPIER GUN OIL', ALTERNATIVELY '3 IN 1' OIL.</i>
<i>PULL-THROUGH PAD :</i>	<i>'NAPIER RIFLE CLEAN', ALTERNATIVELY SOFT COTTON CLOTH.</i>
<i>PULL-THROUGH LINE :</i>	<i>'NAPIER PULL THROUGH KIT', ALTERNATIVELY 20lb FISHING LINE</i>

As a rule cleaners and oils intended for shotguns and small/fullbore weapons are not suitable.

- 1 Cut a piece of line three times the length of your barrel, fold in half and tie ends together. Remove silencer if fitted. Open loading bolt.
- 2 Feed un-knotted end down barrel from the muzzle end until folded end protrudes out 50mm.
- 3 Cut a 100mm length of 'rifle clean' or 100x50mm piece of cloth and pass it between the protruding loop. Spray the pad with 'gun cleaner' or white spirit, turn the rifle upside down and pull the line back through the barrel slowly.
- 4 Repeat steps 2&3 until the pad is clean.
- 5 Repeat steps 2&3 once more without any cleaner on the pad to dry the barrel.
- 6 Repeat steps 2&3 once more with the pad sprayed with 'gun oil' or 3 in 1 oil.

IMPORTANT : THE REASON FOR TURNING THE RIFLE UPSIDE DOWN IS TO PREVENT EXCESS CLEANER/OIL FROM PASSING DOWN THE TRANSFER PORT INTO THE FIRING VALVE CHAMBER.

LUBRICATION

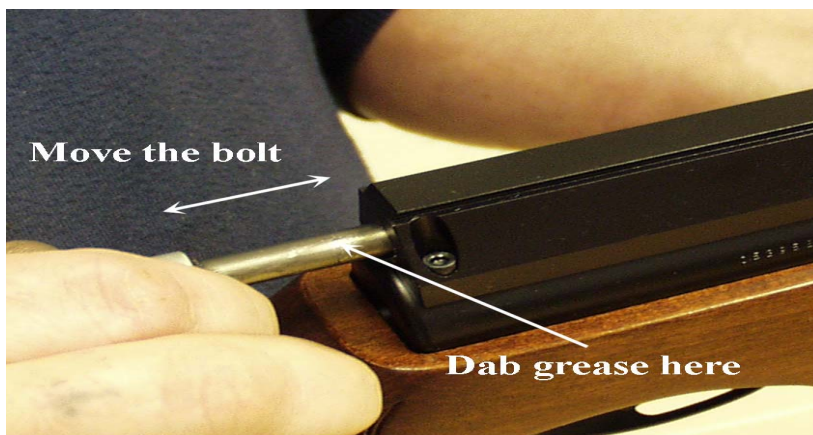

Lubrication of the internal mechanism is not covered in this handbook. This is best performed by a competent gunsmith or the factory and in any case should not be required until the annual service.

Apply a small dab of grease on the loading bolt and work-in by moving the bolt forwards and backwards. Wipe off excessive grease. Preferred grease is 'napier g95 gun grease'.

A small drop of oil should be applied to the magazine O ring to keep it moist, and increase its life span.

On return from every shooting session, wipe all over the exterior with an oily rag to preserve the surface finish during storage.

OPERATING INSTRUCTIONS

COCKING

Hold securely in one hand and with the other turn the loading bolt and pull backwards until the first restriction is felt. Pull back further until the trigger mechanism engages. This can be determined by the trigger blade 'kicking' forward at the end of the cocking stroke.

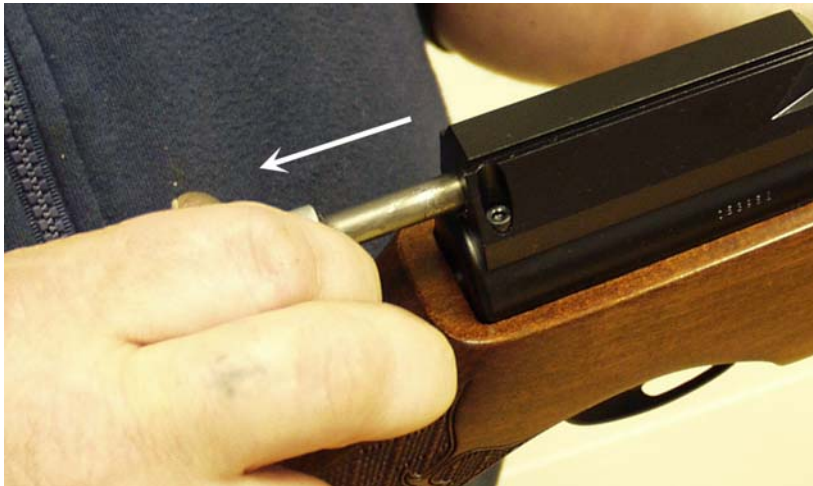

If the bolt is gripped as in the illustration with the thumb on the other side of the bolt knob, the cocking action is much smoother.

Note ! It is very important that the loading bolt is pulled back to the correct position. In one positive motion. The magazine indexes to the next pellet position as the bolt is retracted and it is possible for a partial index if the bolt is not pulled back fully.

If you find the mechanism has not cocked completely but the magazine has indexed, Re-cock but before closing the bolt, remove the magazine and manually index it back to the empty chamber. Replace the magazine and fire as normal. If this procedure is not followed it is likely that you will load a second pellet into the barrel.

Push the bolt forward and push the handle down into its locked position. The rifle is now cocked and ready to fire.



MOUNTING/DEMOUNTING THE MAGAZINE & PELLETS

DEMOUNTING

Fully cock the rifle, grip the magazine as fig.1 and slide out of the bolt housing without lifting. Do not attempt to lift vertically as damage to the indexing spring will result.

To refit the magazine, fully cock the rifle, grip the magazine as fig.2 and slide in the bolt housing applying downward pressure with the fore finger to keep the base of the magazine against the bottom of the slot in the bolt housing. Take care not to damage the indexing spring.



LOADING PELLETS

Hold the magazine as in fig.3 and drop a pellet into the chamber. Manually index to the next empty chamber as in fig.4 and repeat until the magazine is full. Finally line up the red dot on the pellet carrier with the 'v' notch on the clear magazine cover.

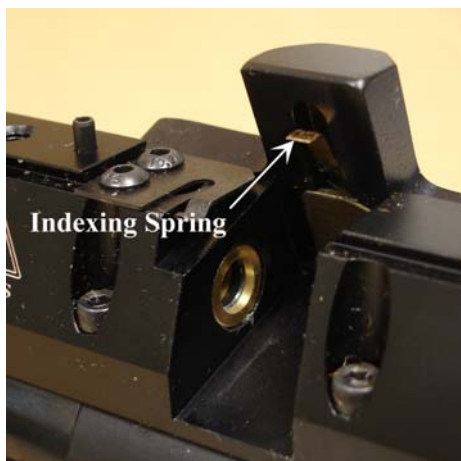
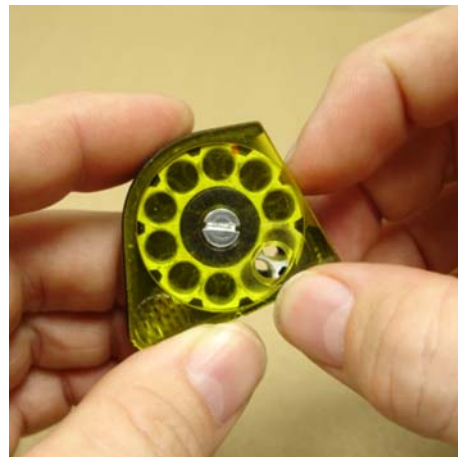
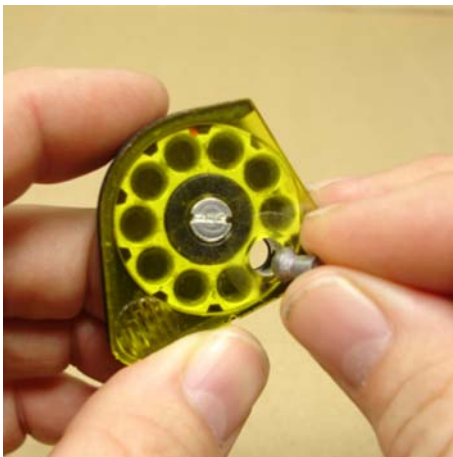

Be very careful not to damage the indexing spring when demounting or mounting the magazine. Follow the instructions carefully.

WARNING *The rifle should only be fired when the magazine is fitted in the breech or damage to the seal carrier may occur.*

A small drop of oil should be applied to the magazine O ring to keep it moist, and increase its life span.

TRIGGER ADJUSTMENTS

The S400 & S410 models all have the same trigger mechanism. It is a two stage unit with adjustment to both stages plus a weight of pull adjustment. It is easy to upset the balance between the two stages and make the trigger inoperable if incorrectly adjusted.

If you have no experience of adjusting two stage triggers seek guidance or leave the trigger as set by the factory.

Note ! Incorrectly adjusted trigger mechanisms are not covered by the manufacturers warranty. It is not possible to test this rifle with an incorrectly adjusted trigger, therefore all triggers leave the factory with correct adjustment.

WARNING ! Please note that it is possible to stop the safety button working with incorrect trigger adjustment.

AN INCORRECTLY ADJUSTED TRIGGER CAN MAKE THE RIFLE UNSAFE TO HANDLE.

DESCRIPTION OF OPERATION

The S400/410 rifles have a true two stage trigger mechanism. This means that as the trigger is pulled the bottom sear gradually disengages with the top sear until the two disengage completely and the rifle goes off. If the pressure on the trigger is released at any point before full disengagement, the bottom sear will automatically return back to full engagement. This type of trigger allows very fine but safe operation because it is the release of the 2nd stage that actually makes the rifle fire. This arrangement is vastly superior to pseudo two stage triggers where the first stage is just a pivoting trigger blade that does not move sears. The down side is that they are more difficult to adjust correctly.

ADJUSTMENT

There are three adjuster screws, a-b-c.

The weight of pull adjuster (a) is located in the front of the trigger guard. Clockwise rotation increases pull weight. If adjusted too far the spring will become coil-bound
And prevent trigger operation.

The second stage adjuster (c) is the rear screw located in the trigger blade. This screw determines the exact point that the 2nd stage starts. If the 1st stage screw is incorrectly adjusted this screw may not have any effect.

The first stage adjuster (b) is the front screw located in the trigger blade. This screw determines the length of travel before the 2nd stage starts. Clockwise adjustment reduces the first stage travel.

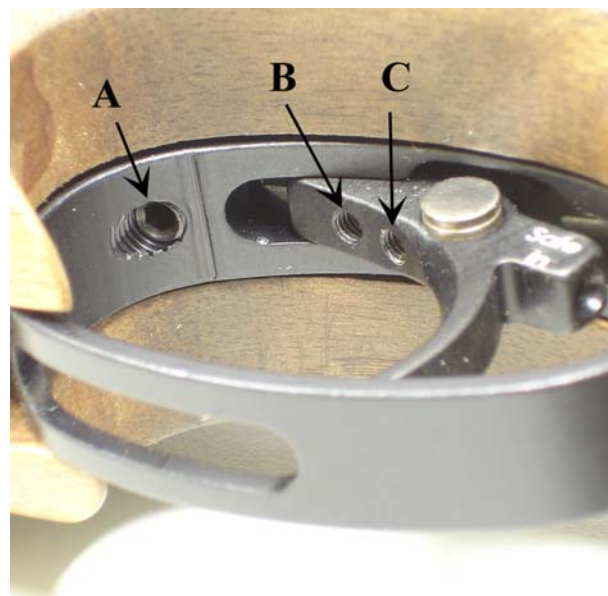

This rifle is fitted with a manual safety button located in the trigger blade.
To make the rifle safe the button must be pressed until it is flush with the side of the trigger blade.

Please note that it is possible to stop the safety button working with incorrect trigger adjustment.

With the button pressed in the rifle is safe.



With the button out the rifle is now ready to fire.

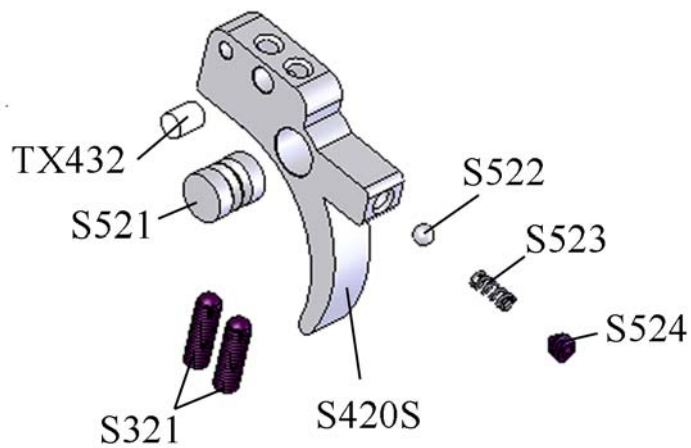

FILLING INSTRUCTIONS

NOTE ! ONLY USE CLEAN, DRY AND FILTERED COMPRESSED AIR, PREFERABLY FROM A DIVING SHOP.

OVER PRESSURISATION MAY DAMAGE THE CYLINDER BEYOND REPAIR.

First the female part of the filling kit (this was supplied with the rifle) must be fitted to your filling equipment. The female part (S475) has a 1/8th BSP male thread that screws directly into the hose of your pump or bottle.



Next remove the dust cover from the end of your rifle.

This is achieved by unscrewing the cover in an anti-clockwise direction.

Once the connector is exposed the female part of the filling kit can be placed on the male and pressed all the way on, making sure that the 'O' rings on the male part are covered.



It is a wise precaution to hold the female part of the connector, during the filling procedure, as shown in the pictures below. This will ensure the female adaptor is located completely over the male part and prevent any accidental dislodging of the connector before you start to refill the cylinder.

Using hand pumps.

The procedure for using hand pumps is the same as for bottle. It is more important to turn the female on the gun to lock it in place.

When using the pump it must be remembered that the first few pumps are filling the hose and NOT the gun. When the pressure in the hose equalises to that in the gun, the gun will start to fill.

It can take some effort to fill the gun using a pump and we recommend using the pump to top up instead of filling from empty.

With the female in place the gun can now be filled.

If the rifle is empty the mechanism will need to be cocked to allow the firing valve to close. If the rifle is not cocked when the bottle is opened or the pump used, the air will past the valve and exhaust through the barrel.

Check that the bleed valve on the filling equipment is closed (turn clockwise to close) then **slowly** open the main valve on bottle or start using the pump. The pressure in the hose will equalise and then the rifle will start to fill.

If you are filling your rifle from empty there may be some air exhausted through the barrel until the air pressure is sufficient to over come the firing valve spring (S306) this will happen at approximately 50 bar (750psi).

The filling pressure of the S400 is 190 bar (2755psi). Filling to a higher pressure will **not** increase either power or number of shots. Over filling will **lower** the power and may cause irreparable damage to the cylinder.

Once the filling pressure has been reached, close the valve on the bottle or stop pumping, open the bleed valve on the filling kit (to vent the hose, if you do not vent the hose you will not be able to remove the female from the rifle). Now the female connector can be removed from the rifle and end cap (S483) can be replaced over the male connector ensuring not to overtighten.



The S400 range of rifles are fitted with a pressure indicator mounted on the underside of the rifle just in front of the stock screw. This provides the user with a visual check on the amount of air remaining in the cylinder this indicator should not be used during the filling process as the needle reaction speed has been slowed to prevent damage whilst filling. After filling the needle can take several seconds to synchronise with the air in the cylinder. The gauge below shows a guns with just over 150 bar of pressure. Although every gun is slightly different the recommended refill pressure for the S400 is between 100 and 110 bar.



NOTE: On the front of the cylinder is an engraved warning reading....

*READ MANUAL. MFP 200bar. MSP 200bar. DOM **/**/** **. INSPECT ANNUALLY.*

*MFP = Maximum Filling Pressure. The pressure is stated.
MSP = Maximum Safe Pressure. The pressure is stated.
DOM = Date of Manufacture. The date is stated.*

WARNING NOTE CONCERNING 300 BAR BOTTLES.

WITH THE ADVENT OF THE 300 BAR BOTTLE IT SHOULD BE NOTED THAT CARE HAS TO BE TAKEN WHEN FILLING YOUR RIFLE.

THE FILLING PROCEDURE DESCRIBED IN THIS MANUAL MUST BE FOLLOWED TO AVOIDED DAMAGE TO THE RIFLE, PARTICULARLY THE SLOW OPENING OF THE VALVE ON THE BOTTLE. OPENING THE VALVE QUICKLY WILL ALLOW UP TO 300 BAR OF PRESSURE INTO THE CYLINDER AT ONCE, THIS COULD CAUSE SERIOUS PERSONAL INJURY OR IRREPARABLE DAMAGE TO THE CYLINDER.

PARTS ILLUSTRATION ◊ S410-C & S410-S

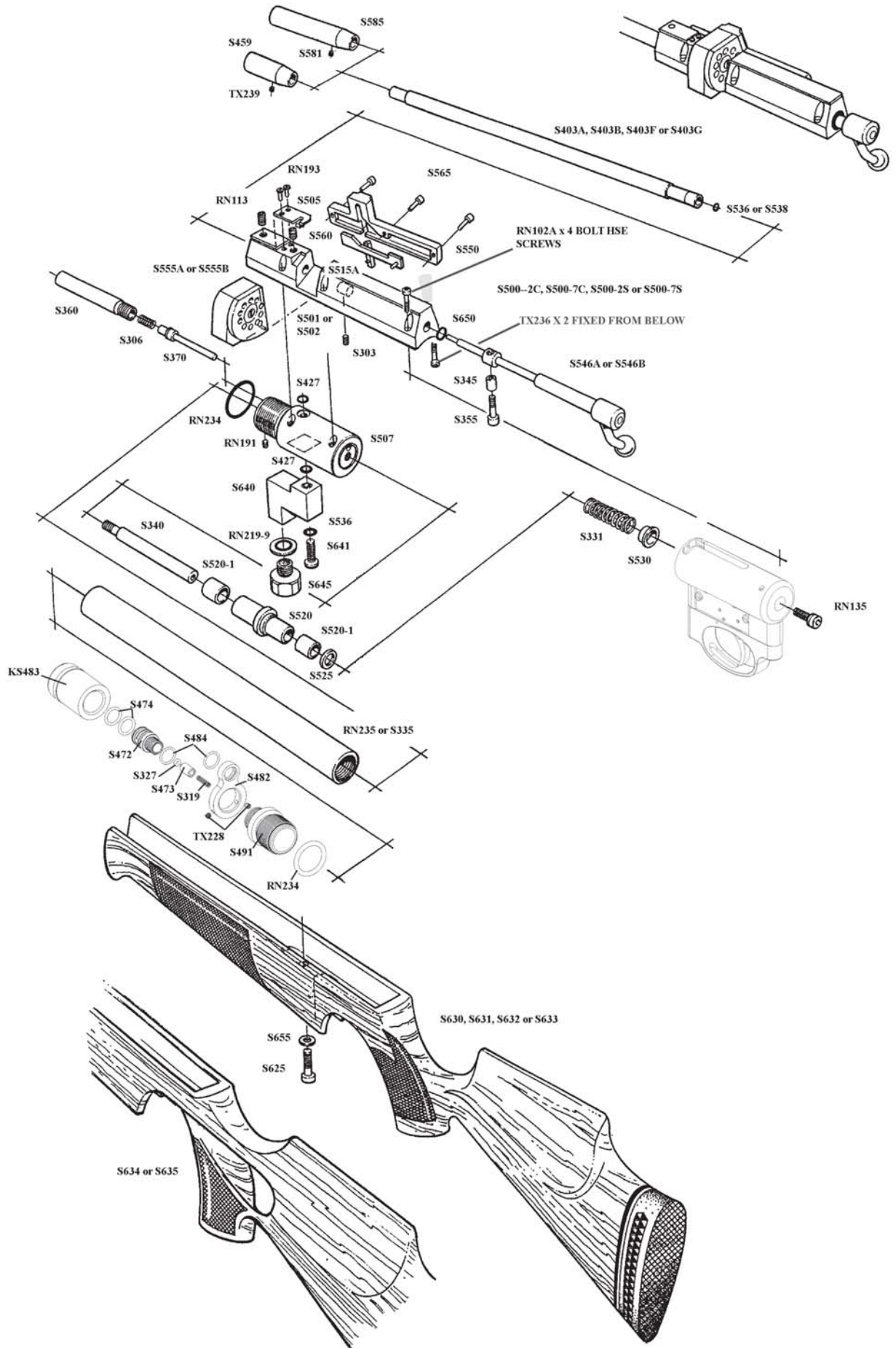

PART LIST <> S410-C & S410-S

PART NO.	DESCRIPTION.	QTY	PART NO.	DESCRIPTION.	QTY
RN102A	BOLT HSE FIXING SCREW	6	S501	BOLT HSE BUSH .22	1
RN113	BARREL FIXING SCREW	2	S502	BOLT HSE BUSH .177	1
RN135	BODY LOCATION SCREW	1	S505	MAG RET CLIP	1
RN191	LOCKING SCREW	1	S507	FIRING VALVE BODY	1
RN193	MAG RET CLIP SCREW	2	S515A	MAG OPERATING POST ASSY	1
RN219-9	PRESSURE GAUGE SEAL	1	S520	STRIKER	1
RN234	SEALING RING	2	S520-1	STRIKER BUSH	2
RN235	CYLINDER TUBE (CARBINE)	1	S525	MAIN SPRING SPACER (OPTION)	1
S303	LOCKING SCREW	1	S530	MAIN SPRING GUIDE	1
S306	FIRING VALVE SPRING	1	S536	BARREL (.177) & GAUGE MOUNT SEAL	2
S319	SPRING	1	S538	BARREL SEAL .22	1
S327	VALVE 'O' RING	1	S546A	LOADING BOLT ASSY .177	1
S331	MAIN SPRING	1	S546B	LOADING BOLT ASSY .22	1
S335	CYLINDER (CLASSIC)	1	S550	SIDE PLATE	1
S340	STRIKER GUIDE ROD	1	S555A	MAG ASSY .177	1
S345	LOADING BOLT SCREW SLEEVE	1	S555B	MAG ASSY .22	1
S355	LOADING BOLT SCREW	1	S560	CAMPLATE	1
S360	FIRING POT	1	S565	SIDE PLATE SCREW	3
S370	FIRING VALVE ASSEMBLY	1	S581	MODERATOR SCREW	1
S403A	BARREL .22 (CLASSIC)	1	S585S	SOUND MODERATOR (OPTION)	1
S403B	BARREL .177(CLASSIC)	1	S625	STOCK SCREW	1
S403F	BARREL .22 (CARBINE)	1	S630	BEECH STOCK RH	1
S403G	BARREL .177 (CARBINE)	1	S631	BEECH STOCK LH	1
S427	BOLT HSE TO BODY SEAL	2	S632	WALNUT STOCK RH	1
S459	MUZZLE END	1	S633	WALNUT STOCK LH	1
S472	MALE ADAPTOR	1	S634	THUMBHOLE STOCK RH	1
S473	VALVE	1	S635	THUMBHOLE STOCK LH	1
S474	12x2 'O' RING	2	S640	PRESSURE GAUGE MOUNT	1
S475	FEMALE ADAPTOR	1	S641	GAUGE MOUNT SCREW	1
S482	FRONT CYLINDER CLAMP	1	S645	PRESSURE GAUGE	1
KS483	CYLINDER END CAP	1	S650	LOADING BOLT BUFFER	1
S484	FRONT CLAMP RING	2	S655	STOCK SCREW WASHER	1
S491	FILLING VALVE BODY	1	TX228	CYLINDER CLAMP SCREW	2
S500-2C	BOLT HSE .22 CARBINE	1	TX239	MUZZLE END SCREW	1
S500-2S	BOLT HSE .22 CLASSIC	1			
S500-7C	BOLT HSE ..177 CARBINE	1			
S500-7S	BOLT HSE .177 CLASSIC	1			

PLEASE STATE YOUR RIFLE NUMBER IN ANY CORRESPONDENCE.

ITEM NO.	PART No	DESCRIPTION	QTY.	ITEM NO.	PART No	DESCRIPTION	QTY.
1	S312	TRIGGER CHASSIS	1	16	S523	SAFETY BUTTON SPRING	1
2	TX398	3x11.8 ROLLER	1	17	S524	SAFETY BUTTON SCREW	1
3	S326	2x11.8 ROLLER	4	18	S319	WEIGHT OF PULL SPRING	1
4	S320-2	TOP SEAR	1	19	S430	COVER PLATE	1
5	S328	BS005 O RING	1	20	S324	M3X5 CHEESE HEAD	1
6	S325-2	MIDDLE SEAR	1	21	S322	M4X12 CSK SCREW	1
7	S321-2	BOTTOM SEAR	1	22	TX236	M4X16 SOC CAP	1
8	S329	BS004 O RING	2	23	S315	TRIGGER GUARD	1
9	S495	TOP SEAR SPRING	1	24	RN170	BISSEL PIN	1
10	S496	M3x6 CAP	1	25	TX381	WEIGHT OF PULL SCREW	1
11	S420S	TRIGGER BLADE	1	26	S316	M4X25 SOC CAP	1
12	S421	TRIGGER ADJ SCREW	2	27	TX460	M4X12 SOC CAP	1
13	TX432	LOCKING PAD	1	28	S310AT	STRIKER BODY ANTI-TAMPER	1
14	S521	SAFETY BUTTON	1	29	S425	2x15.8 Roller	1
15	S522	SAFETY BUTTON BALL	1				

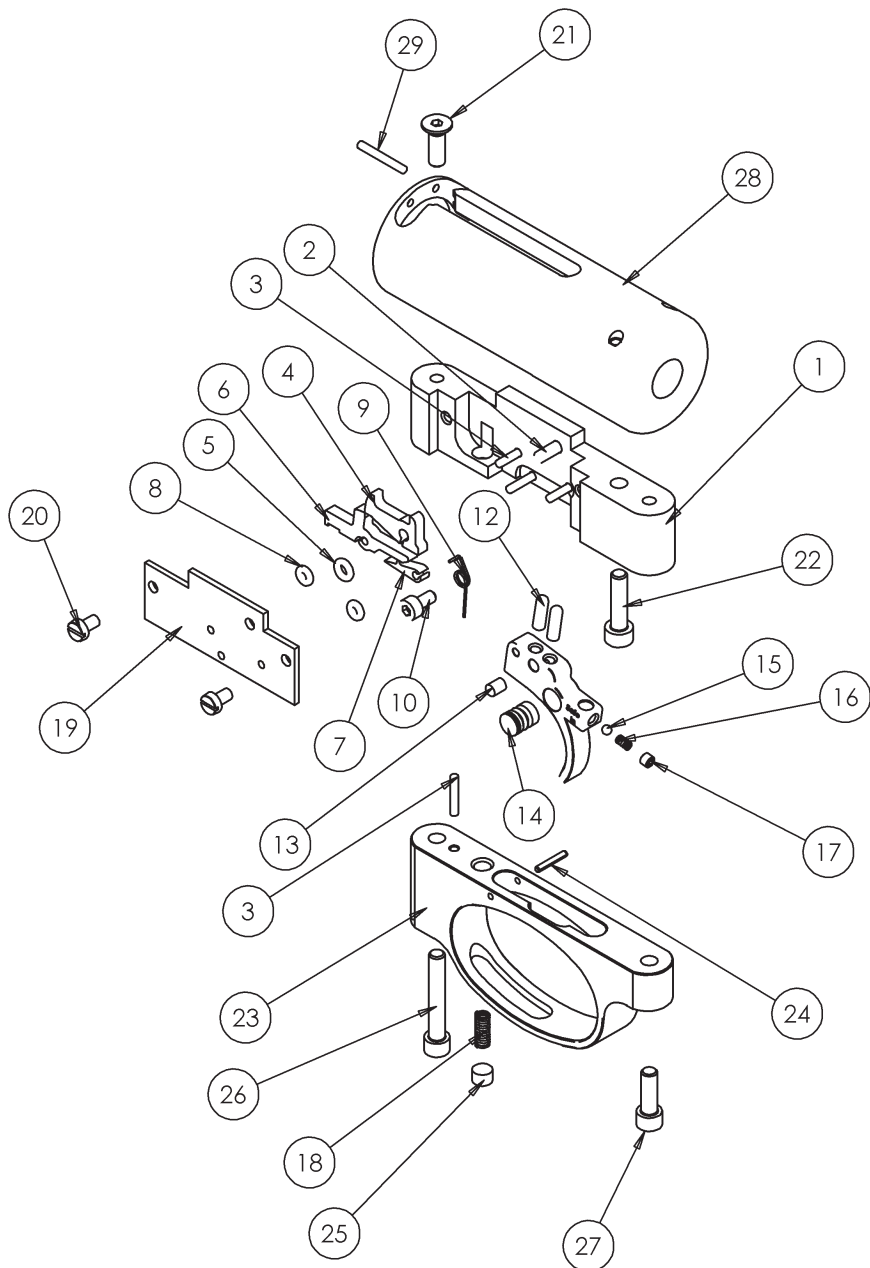

Air Arms, Unit 6, Hailsham Industrial Park, Diplocks
Way, Hailsham, East Sussex, England BN27 3JF.

Tel: 01323 845853. Fax: 01323 440573.

Website: www.air-arms.co.uk

Email: general@air-arms.co.uk

Notes