

MODEL
S410F & SUPERLITE
RIFLE & CARBINE



USERS HANDBOOK

THIS HANDBOOK REFERS TO S410F CLASSIC & CARBINE MODELS



Model shown with optional scope and moderator.

***** SAFETY CODE *****

- 1 - TREAT THIS AIR RIFLE AS IF LOADED.
- 2 - NEVER POINT IT AT ANYONE, EVEN IF UNLOADED.
- 3 - NEVER LEAVE THIS RIFLE UNATTENDED WHEN COCKED OR LOADED.
- 4 - ALWAYS BE SURE OF WHAT LIES BEYOND YOUR TARGET.
- 5 - ALWAYS CONDUCT YOURSELF IN A SPORTSMAN-LIKE MANNER.

ALWAYS BE AWARE THAT YOUR ACTIONS WILL BE UNDER THE SCRUTINY OF OTHER MEMBERS OF THE PUBLIC WHO MAY NOT SHARE YOUR ENTHUSIASM FOR AIR WEAPONS. BAD PRACTICES PROMOTE BAD PUBLICITY. DO NOT JEOPARDISE YOUR FUTURE ENJOYMENT BY MISUSING THIS WEAPON.

Gun security

It is important to make sure that your gun is always kept in a safe and secure fashion when not in use.

For rifles purchased in the UK and that are NOT FAC rated (high power) a free gun lock and mounting eyes are supplied. Please follow the simple fixing instructions and keep our sport safe.

Note: If there is no gun lock in the box please contact the dealer you purchased the rifle from.



PLEASE READ THIS MANUAL BEFORE USING YOUR NEW RIFLE, IT
CONTAINS IMPORTANT SAFETY INFORMATION AND INSTRUCTION ON
ADJUSTMENT AND MAINTENANCE.

WARNING ! - UNAUTHORISED DISASSEMBLY OF THIS RIFLE WILL INVALIDATE THE MANUFACTURERS WARRANTY

Important information

Before leaving the factory this rifle was Q.A. inspected and test fired using Air Arms pellets to check operation and final adjustment.

It was dispatched in a sealed purpose designed box with a contents label on the lid. Air Arms may not be responsible for any damage to the contents or missing items if the box is not original, if it is damaged or the seals are not intact.

Air Arms cannot be held responsible for damage or missing items due to transit damage, mishandling or being tampered with after leaving the factory.

If this rifle is not received in the original box with the seals intact, please examine carefully for any damage, missing tools or documentation.

In the first instance any problems or complaints regarding this product should be referred to the supplier.

The air cylinder is a highly pressurised unit that must not be modified in any way. Serious personal injury may result if this, and the advice below is not followed.

Do not pressurize the cylinder if there are any surface abrasions or dents. Contact Air Arms for advice.

Do not store the rifle in places with, or near sources of high temperature such as fires or boilers.

Do not attempt to dismantle when pressurised.

Do not pressurize beyond the stated filling pressure (see filling instruction section). Damage caused by such action is not covered by the manufacturers warranty.

Only use clean, filtered and dry compressed air. Never use any other gas, particularly industrial or welding gases such as oxygen, carbon dioxide, acetylene, hydrogen, argon, etc.

If compressed air is being used other than from a diving shop, the inside of the cylinder should be inspected for corrosion at least annually. If in doubt contact Air Arms for advice.

In any event the cylinder should be inspected every two to three years depending upon usage.

Air Arms can provide this service at a reasonable cost.

To maintain this rifle in good working order it should be serviced annually by a competent gunsmith, your supplier may be able to provide this service or contact air arms.

A reasonable amount of advice will be provided to enable the end user to service their own rifle, however this is at the discretion of Air Arms and may not be given in all cases.

The velocity of this rifle has been set using Air Arms field pellets. If any other make or type of pellet is to be used the rifle must be re-tested with the pellet that is to be used, to ensure the muzzle energy is within the limits determined by current legislation.

Due to the nature of hand pumps and their relative inefficiency in removing moisture from the compressed air, the chances of corrosion damage to the cylinder and other internal components are increased.

Therefore the rifle should be regularly serviced and/or checked for any signs of damage by a competent gunsmith.

Air Arms recommend using a dry pack filter kit on any hand pumps used to fill our air rifles.

If accessories not manufactured by Air Arms are used on this rifle, Air Arms can not be held responsible for any loss of performance. Contact your supplier or Air Arms for any advice on this matter.

Do not store this rifle in a damp place such as garden shed or garage.

Do not store this rifle in a plastic or PVC gun bag without first applying a surface corrosion inhibitor.

Always ensure the loading bolt is fully closed before firing.

Important information continued

CHECKING VELOCITY

- 1 Use a reliable chronograph to check velocity, (the formula below requires the reading to be in feet per second - FPS)
- 2 Use fine measurement scales to weigh the pellet, If scales are unavailable the pellet weight may be stated on the pellet container lid or contact the supplier. (The formula requires the weight to be in grains). To convert from grams to grains multiply by 15.432, i.e. 0.69 grams x 15.432 = 10.65 grains.
- 3 To find the muzzle energy in ft/lbs use the formula $(FPS \times FPS \times Grains) / 450240$, i.e. $(700 \times 700 \times 10.65) = 5218500$ divide by 450240 = 11.59.

CURRENT LEGISLATION LIMITS NON-FAC HOLDERS, IN THE UK, TO AIR RIFLES WITH A MAXIMUM OF 12ft/lbs MUZZLE ENERGY.

WARNING! IT IS A VERY SERIOUS OFFENCE TO BE IN POSSESSION OF AN AIR RIFLE THAT YOU ARE NOT CERTIFICATED FOR. CONVICTION CAN RESULT IN CONFISCATION OF YOUR RIFLE, A HEAVY FINE OR IMPRISONMENT, EVEN A COMBINATION OF ALL THREE.

***** LIMITED LIABILITY WARRANTY ***** UK Customers only.

This product is warranted to the retail customer for 12 months from date of purchase against defects in materials and workmanship and is transferable to any subsequent owner.

Proof of purchase is required to receive warranty repairs, retain your purchase invoice and return the warranty registration card as soon as possible after purchase. The warranty card must show the dealer/supplier name and address and date of purchase.

What is covered

Replacement parts & labour on a 'back to base' basis, return transportation to the consumer (mainland UK only).

What is not covered

Transportation from the consumer to Air Arms.

Damage caused by misuse, abuse, lack of routine maintenance, transit damage between the dealer/supplier and the consumer or unauthorized disassembly.

Parts subject to normal wear and tear.

Any other consequential cost incurred by the consumer.

Return transportation to consumers outside mainland UK.

No warranty is implied as to the fitness for any particular purpose.

AIR ARMS RESERVE THE RIGHT TO ALTER THE CONSTRUCTION, APPEARANCE OR PERFORMANCE OF ANY PRODUCT WITHOUT PRIOR NOTIFICATION. ALL ILLUSTRATIONS ARE FOR INFORMATION PURPOSES ONLY AND DO NOT NECESSARILY SHOW THE EXACT MODEL THAT WAS PURCHASED.

OPERATING INSTRUCTIONS

COCKING

Hold securely in one hand and with the other turn the loading bolt and pull backwards until the first restriction is felt. Pull back further until the trigger mechanism engages. This can be determined by the trigger blade 'kicking' forward at the end of the cocking stroke.

If the bolt is gripped as in the illustration with the thumb on the other side of the bolt knob, the cocking action is much smoother.



Note! It is very important that the loading bolt is pulled back to the correct position. In one positive motion. The magazine indexes to the next pellet position as the bolt is retracted and it is possible for a partial index if the bolt is not pulled back fully.

If you find the mechanism has not cocked completely but the magazine has indexed, Re-cock but before closing the bolt, remove the magazine and manually index it back to the empty chamber.

Replace the magazine and fire as normal. If this procedure is not followed it is likely that you will load a second pellet into the barrel.

Push the bolt forward and push the handle down into its locked position. The rifle is now cocked and ready to fire.

MOUNTING/DEMOUNTING THE MAGAZINE & PELLETS

DEMOUNTING

Fully cock the rifle, grip the magazine and slide out of the bolt housing without lifting. **Do not** attempt to lift vertically as damage to the indexing spring will result.

To refit the magazine, fully cock the rifle, grip the magazine and slide in the bolt housing applying downward pressure with the fore finger to keep the base of the magazine against the bottom of the slot in the bolt housing. Take care not to damage the indexing spring.

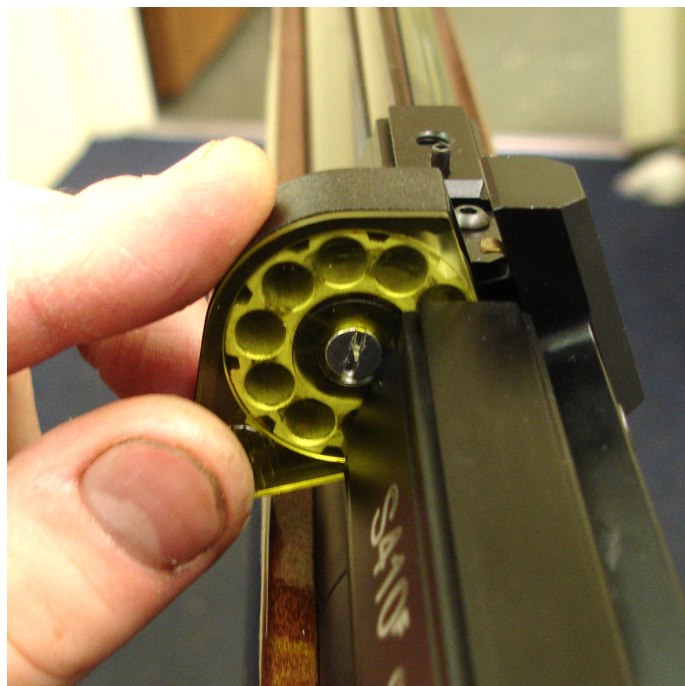

LOADING PELLETS

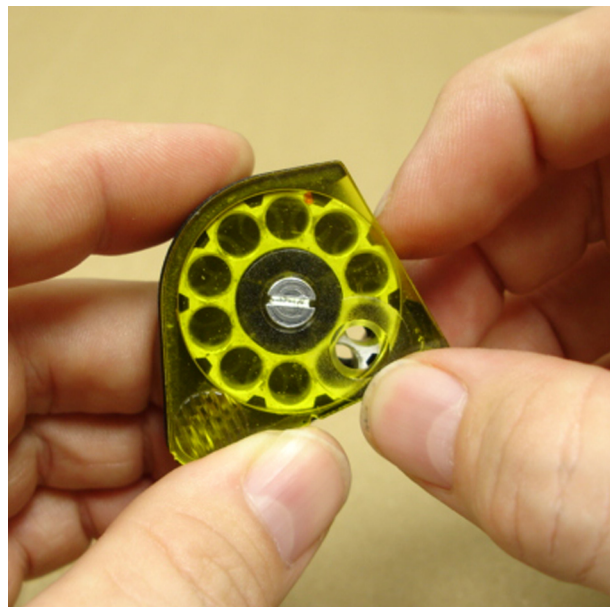
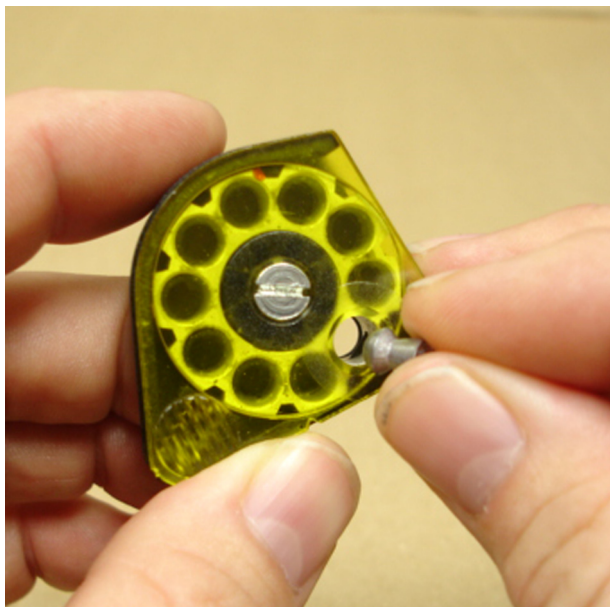

Hold the magazine and drop a pellet into the chamber. Manually index to the next empty chamber and repeat until the magazine is full.

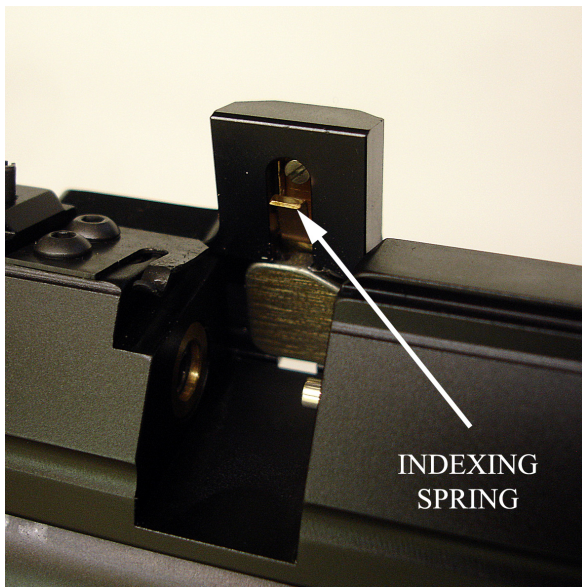

Be very careful not to damage the indexing spring when de-mounting or mounting the magazine. Follow the instructions carefully.

A small drop of oil should be applied to the magazine 'O' ring to keep it moist, and increase its life span.

TRIGGER ADJUSTMENTS

The S400F & S410F models all have the same trigger mechanism. It is a two stage unit with adjustment to both stages plus a weight of pull adjustment. It is easy to upset the balance between the two stages and make the trigger inoperable if incorrectly adjusted.

If you have no experience of adjusting two stage triggers seek guidance or leave the trigger as set by the factory.

Note! Incorrectly adjusted trigger mechanisms are not covered by the manufacturers warranty. It is not possible to test this rifle with an incorrectly adjusted trigger, therefore all triggers leave the factory with correct adjustment. **WARNING!** Please note that it is possible to stop the safety button working with incorrect trigger adjustment. AN INCORRECTLY ADJUSTED TRIGGER CAN MAKE THE RIFLE UNSAFE TO HANDLE.

DESCRIPTION OF OPERATION

The S400F & S410F rifles have a true two stage trigger mechanism. This means that as the trigger is pulled the bottom sear gradually disengages with the top sear until the two disengage completely and the rifle goes off. If the pressure on the trigger is released at any point before full disengagement, the bottom sear will automatically return back to full engagement. This type of trigger allows very fine but safe operation because it is the release of the 2nd stage that actually makes the rifle fire. This arrangement is vastly superior to pseudo two stage triggers where the first stage is just a pivoting trigger blade that does not move sears. The down side is that they are more difficult to adjust correctly.

ADJUSTMENT

There are three adjuster screws, A-B-C. The weight of pull adjuster (A) is located in the front of the trigger guard. Clockwise rotation increases pull weight. If adjusted too far the spring will become coil-bound and prevent trigger operation.

The second stage adjuster (C) is the rear screw located in the trigger blade. This screw determines the exact point that the 2nd stage starts. If the 1st stage screw is incorrectly adjusted this screw may not have any effect.

The first stage adjuster (B) is the front screw located in the trigger blade. This screw determines the length of travel before the 2nd stage starts. Clockwise adjustment reduces the first stage travel.

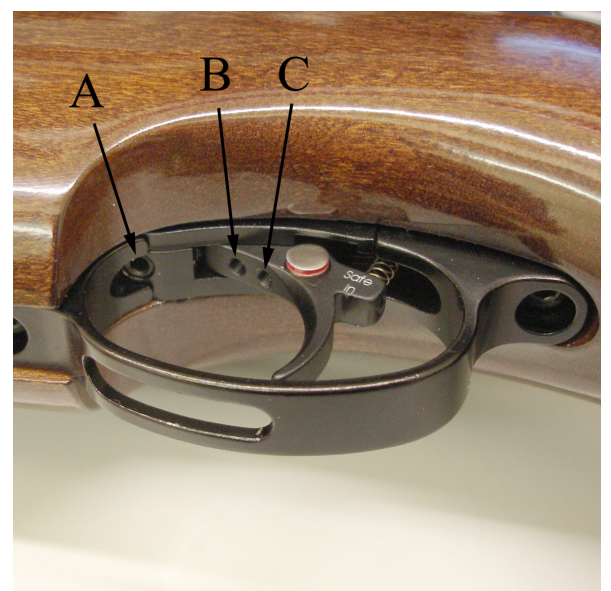

This rifle is fitted with a manual safety button located in the trigger blade.

To make the rifle safe the button must be pressed until it is flush with the side of the trigger blade.

Please note that it is possible to stop the safety button working with incorrect trigger adjustment.



With the button pressed in the rifle is safe.

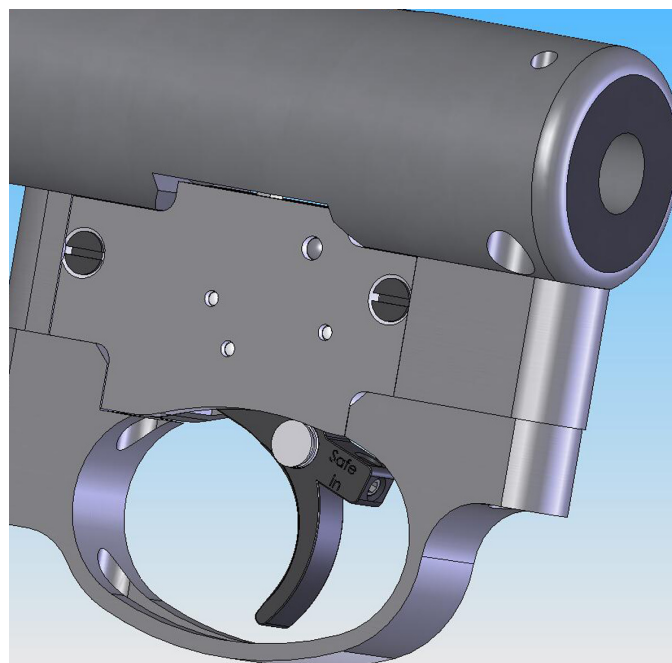

With the button out the rifle is now ready to fire.

ITEM NO.	PART NUMBER	DESCRIPTION	QTY.
1	S420S-2	TRIGGER BLADE - BLACK ANODIZED	1
	S420GS-2	TRIGGER BLADE - GOLD PLATED	
2	S521-2A	SAFETY BUTTON - PART ONE	1
3	S521-2B	SAFETY BUTTON - PART TWO	1
4	S526	SAFETY BUTTON O RING	1
5	S523	BALL BEARING	1
6	S522	SAFETY BUTTON SPRING	1
7	S524	SCREW	1
8	TX432	ADJUSTER SCREW LOCKING PAD	1
9	S421	SCREW	2

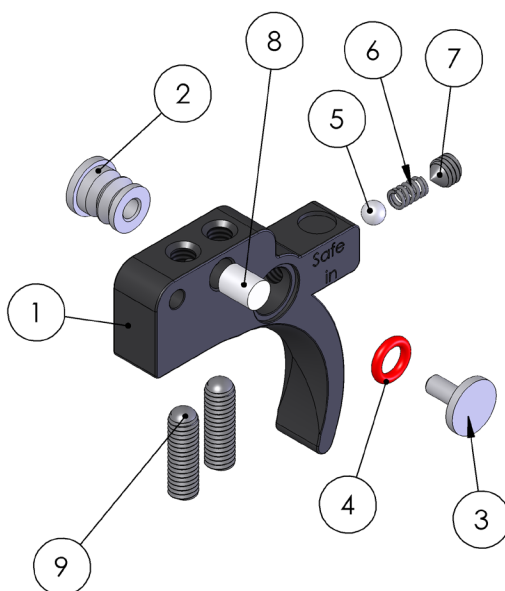

FILLING INSTRUCTIONS

NOTE! ONLY USE CLEAN, DRY AND FILTERED COMPRESSED AIR, PREFERABLY FROM A DIVING SHOP. OVER PRESSURIZATION MAY DAMAGE THE CYLINDER BEYOND REPAIR.

First the female part of the filling kit (this was supplied with the rifle) must be fitted to your filling equipment. The female part (S475) has a 1/8th BSP male thread that screws directly into the hose of your pump or bottle.

Next remove the dust cover from the end of your rifle. This is achieved by unscrewing the cover in an anti-clockwise direction.



Once the connector is exposed the female part of the filling kit can be placed on the male and pressed all the way on, making sure that the 'O' rings on the male part are covered.

It is a wise precaution to hold the female part of the connector during the filling procedure, as shown in the pictures below. This will ensure the female adaptor is located completely over the male part and prevent any accidental dislodging of the connector before you start to refill the cylinder.

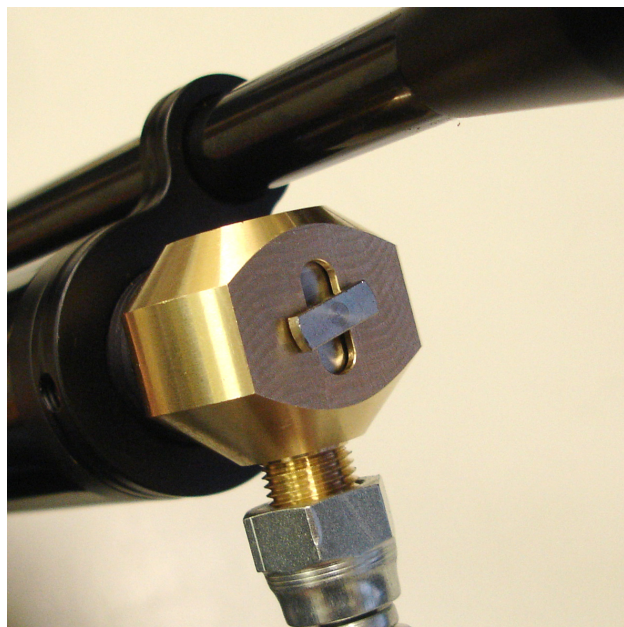
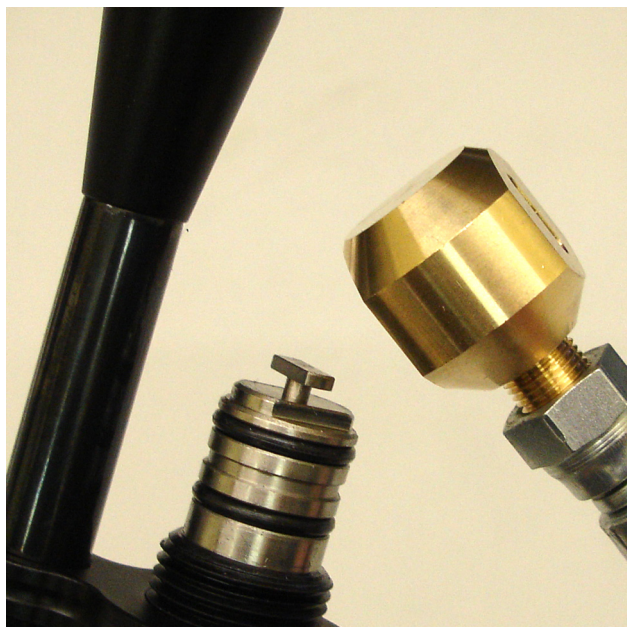

Using hand pumps

The procedure for using hand pumps is the same as for bottle. It is more important to turn the female on the gun to lock it in place.

When using the pump it must be remembered that the first few pumps are filling the hose and NOT the gun. When the pressure in the hose equalizes to that in the gun, the gun will start to fill.

It can take some effort to fill the gun using a pump and we recommend using the pump to top up instead of filling from empty.

With the female in place the gun can now be filled.

If the rifle is empty the mechanism will need to be cocked to allow the firing valve to close. If the rifle is not cocked when the bottle is opened or the pump used, the air will past the valve and exhaust through the barrel.

Check that the bleed valve on the filling equipment is closed (turn clockwise to close) then slowly open the main valve on bottle or start using the pump. The pressure in the hose will equalise and then the rifle will start to fill.

If you are filling your rifle from empty there may be some air exhausted through the barrel until the air pressure is sufficient to over come the firing valve spring (S306) this will happen at approximately 50 bar (750psi).

The filling pressure of the S410F is 190 bar (2755psi). Filling to a higher pressure will not increase either power or number of shots. Over filling will lower the power and may cause irreparable damage to the cylinder.

Once the filling pressure has been reached, close the valve on the bottle or stop pumping, open the bleed valve on the filling kit (to vent the hose, if you do not vent the hose you will not be able to remove the female from the rifle). Now the female connector can be removed from the rifle and end cap (S483) can be replaced over the male connector ensuring not to overtighten.

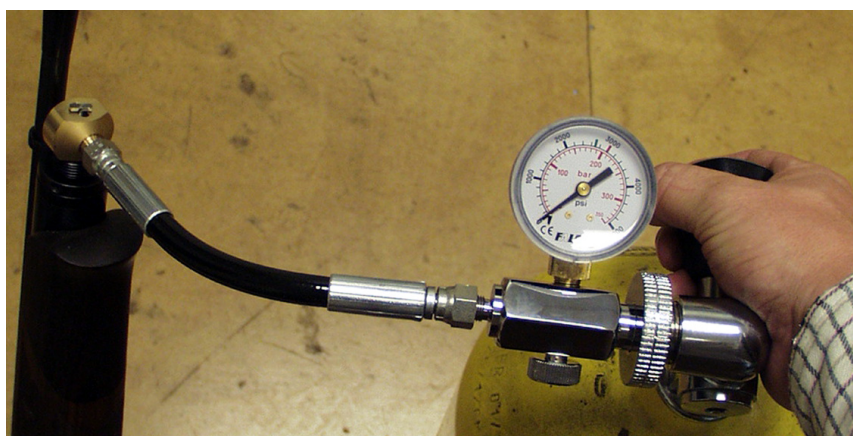

The S410F range of rifles are fitted with a pressure indicator mounted on the underside of the rifle just in front of the stock screw. This provides the user with a visual check on the amount of air remaining in the cylinder this indicator should not be used during the filling process as the needle reaction speed has been slowed to prevent damage whilst filling. After filling the needle can take several seconds to synchronize with the air in the cylinder. The gauge below shows a guns with just over 150 bar of pressure. Although every gun is slightly different the recommended refill pressure for the S410F is between 100 and 110 bar. **Always use the gauge on the filling kit.**

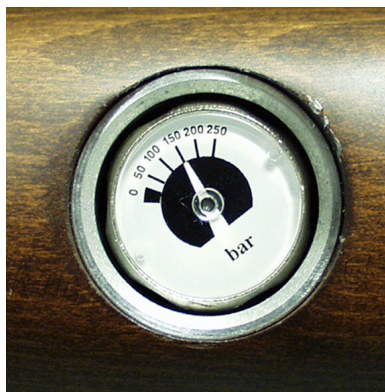

NOTE: On the front of the cylinder is an engraved warning reading...

READ MANUAL. MFP 200bar. MSP 200bar. DOM **/**/** **.
INSPECT BI-ANNUALLY.

MFP = Maximum Filling Pressure. The pressure is stated.
MSP = Maximum Safe Pressure. The pressure is stated.
DOM = Date of Manufacture. The date is stated.

WARNING NOTE CONCERNING 300 BAR BOTTLES.

WITH THE ADVENT OF THE 300 BAR BOTTLE IT SHOULD BE NOTED THAT CARE HAS TO BE TAKEN WHEN FILLING YOUR RIFLE.

THE FILLING PROCEDURE DESCRIBED IN THIS MANUAL MUST BE FOLLOWED TO AVOIDED DAMAGE TO THE RIFLE, PARTICULARLY THE SLOW OPENING OF THE VALVE ON THE BOTTLE. OPENING THE VALVE QUICKLY WILL ALLOW UP TO 300 BAR OF PRESSURE INTO THE CYLINDER AT ONCE, THIS COULD CAUSE SERIOUS PERSONAL INJURY OR IRREPARABLE DAMAGE TO THE CYLINDER.

MAINTENANCE

FIXINGS

Regularly check the tightness of all fixings. However do not be tempted to over tighten as some parts are made from aluminium and stripped threads may result. Stripped threads are not covered by the manufacturers warranty.

BARREL

For ultimate accuracy, clean and re-lube the barrel frequently. It is difficult to advise how often is best for every circumstance, but every 250 shots is not too often if the desire is to keep the barrel in the best possible condition.

The correct materials are very important. Air arms only uses products made by Napier. Listed below is the Napier product and a more generally available alternative. If possible use napier for the best results.

CLEANER:	‘NAPIER GUN CLEANER’, ALTERNATIVELY WHITE SPIRIT.
OIL:	‘NAPIER GUN OIL’, ALTERNATIVELY ‘3 IN 1’ OIL.
PULL-THROUGH PAD:	‘NAPIER RIFLE CLEAN’, ALTERNATIVELY SOFT COTTON CLOTH.
PULL-THROUGH LINE:	‘NAPIER PULL THROUGH KIT’, ALTERNATIVELY 20lb FISHING LINE

As a rule cleaners and oils intended for shotguns and small/full-bore weapons are not suitable.

1. Cut a piece of line three times the length of your barrel, fold in half and tie ends together. Remove silencer if fitted. Open loading bolt.
2. Feed un-knotted end down barrel from the muzzle end until folded end protrudes out 50mm.
3. Cut a 100mm length of ‘rifle clean’ or 100 x 50mm piece of cloth and pass it between the protruding loop. Spray the pad with ‘gun cleaner’ or white spirit, turn the rifle upside down and pull the line back through the barrel slowly.
4. Repeat steps 2&3 until the pad is clean.
5. Repeat steps 2&3 once more without any cleaner on the pad to dry the barrel.
6. Repeat steps 2&3 once more with the pad sprayed with ‘gun oil’ or 3 in 1 oil.

IMPORTANT : THE REASON FOR TURNING THE RIFLE UPSIDE DOWN IS TO PREVENT EXCESS CLEANER/OIL FROM PASSING DOWN THE TRANSFER PORT INTO THE FIRING VALVE CHAMBER.

LUBRICATION

Lubrication of the internal mechanism is not covered in this handbook. This is best performed by a Air Arms or a competent gunsmith and in any case should not be required until the annual service.

Apply a small dab of grease on the loading bolt and work-in by moving the bolt forwards and backwards. Wipe off excessive grease. Preferred grease is 'Napier g95 gun grease'.

A small drop of oil should be applied to the magazine O ring to keep it moist, and increase its life span. On return from every shooting session, wipe all over the exterior with an oily rag to preserve the surface finish during storage.

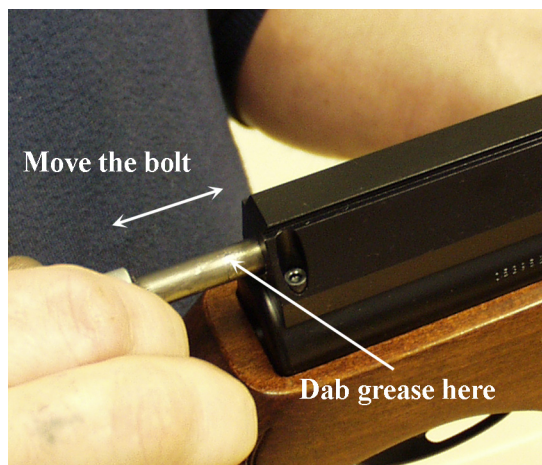

ITEM NO.	PART NUMBER	DESCRIPTION	QTY.	ITEM NO.	PART NUMBER	DESCRIPTION	QTY.
1	S313	CHASSIS	1	16	RN191	SCREW	1
2	S320-2	TOP SEAR	1	17	TX381	SCREW	1
3	S321-2	BOTTOM SEAR	1	18	S319	FILLING VALVE SPRING	1
4	S325-2	MIDDLE SEAR	1	19	TX236	SCREW	1
5	S420S-2	TRIGGER BLADE - MK2	1	20	S496	SCREW	1
6	S318	COVER PLATE	1	21	TX460	SCREW	1
7	S314	TRIGGER GUARD	1	22	S316	SCREW	1
8	S317	STRIKER BODY	1	23	S495	TOP SEAR SPRING	1
9	TX398	PIN	1	24	S311	TRIGGER LOAD SPRING	1
10	S326	PIN	3	25	RN106	SCREW	2
11	S523	BALL BEARING	1	26	S425	PIN	1
12	S522	SAFETY BUTTON SPRING	1	27	S322	SCREW	1
13	S524	SCREW	1	28	S521-2A	SAFETY BUTTON - PART ONE	1
14	S421	SCREW	2	29	S521-2B	SAFETY BUTTON - PART TWO	1
15	TX432	ADJUSTER SCREW LOCKING PAD	1	30	S526	SAFETY BUTTON O RING	1

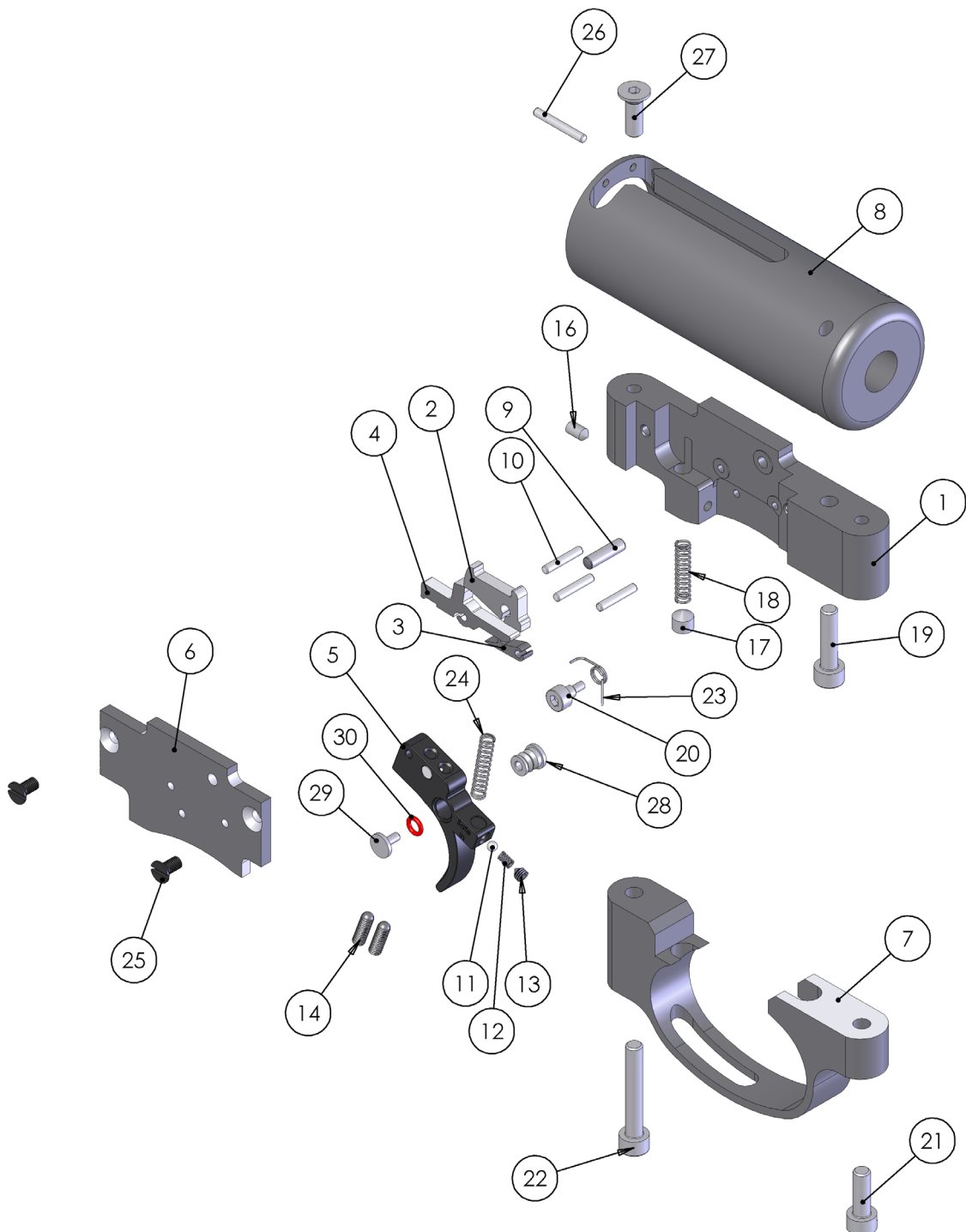

ITEM NO.	PART NUMBER	DESCRIPTION	QTY.	ITEM NO.	PART NUMBER	DESCRIPTION	QTY.
1	S507-SL	FIRING VALVE BODY	1	29	S505	MAGAZINE RETAINING CLIP	1
2	E146	FRICION PAD	1	30	S550	SIDE PLATE	1
3	S370	FIRING VALVE ASSY	1	31	S560	CAM PLATE	1
4	S306	FIRING VALVE SPRING	1	32	S515A	INDEXING POST ASSY	1
5	S360	POT	1	33	S555A	MAGAZINE - .22	1
6	S640AT	GAUGE MOUNT	1	34	S555B	MAGAZINE - .177	1
7	S340	STRIKER ROD	1	35	S365	POT SPRING GUIDE	1
8	S595	S410 BOLT HOUSING	1	36	S331	MAIN SPRING	1
9	S540A	LOADING BOLT - .177	1	37	RN113	M5 X 6 SKT SET CUP PT	2
	S540B	LOADING BOLT - .22		38	S680AT	ANTI TAMPER SCREW	1
10	S345	SLEEVE	1	39	S427	6 X 1 NBR70	2
11	S355	M4 X 14 SKT CAP	1	40	RN234	BS213 NBR70	2
12	S545-4	BOLT KNOB	1	41	TX228	M4 X 4 SKT SET FT PT	4
13	S545-1	BOLT SLEEVE	1	42	S536	BS008 NBR70	1
14	S520	STRIKER	1	43	JT416	M5 X 18 SKT BTN	1
15	S520-1	BEARING	2	44	RN219-9	BS011 NBR70	1
16	S530	MAIN SPRING GUIDE	1	45	S645	INDICATOR GAUGE	1
17	S491	FILLING VALVE BODY	1	46	TX239	M3 X 3 SKT SET FT PT	1
18	S473	FILLING VALVE	1	47	RN191	M3 X 5 SKT SET CONE PT TUFF LOC	1
19	S472	MALE CONNECTOR	1	48	TX236	M4 X 16 SKT CAP	2
20	S471	SINTERED FILTER	1	49	RN102A	M3 X 16 SKT CAP	5
21	S335	CYLINDER - RIFLE	1	50	S327	BS005 NBR90	1
	RN235	CYLINDER - CARBINE		51	S484	12 X 1.5 NBR70	2
22	S401A	BARREL - RIFLE .22	1	52	S319	FILLING VALVE SPRING	1
	S401B	BARREL - RIFLE .177		53	S474	12 X 2 NBR70	2
	S401F	BARREL - CARBINE .22		54	FP121	BARREL SEAL - .177	1
	S401G	BARREL - CARBINE .177		55	S538	BARREL SEAL - .22	1
23	S402A	BARREL SEAL CARRIER - .22	1	56	S650	8 X 1.25 NBR70	1
24	S402B-2	BARREL SEAL CARRIER - .177	1	57	E483BK	END CAP - BLACK	1
25	S485	BARREL CLAMP - MK2	1	58	RN135	M6 X 16 SKT CAP ST/ST	1
26	S458	MUZZLE END - MK2	1	59	S303	M3 X 3 SKT SET FT PT	1
27	S605	MUZZLE INSERT - BLACK	1	60	RN193	M3 X 6 SKT BTN	2
28	S400F TRIGGER MECH		1	61	S565	M3 X 8 SKT CAP	3
	S501	BOLT HSE BUSH - .22		62	S650A	8 X 1 NBR70	2
	S502	BOLT HSE BUSH - .177					

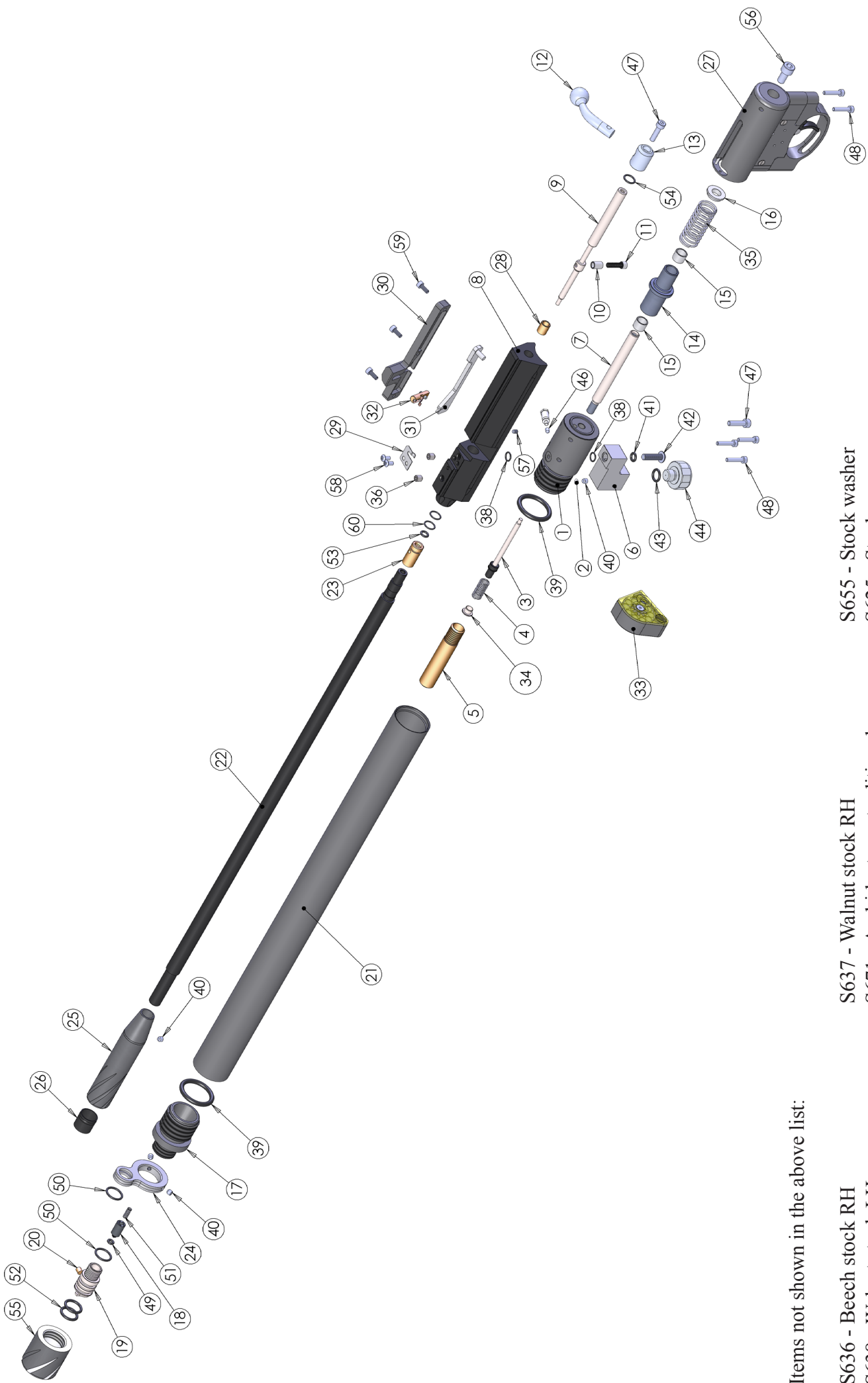

Items not shown in the above list:

- S636 - Beech stock RH
- S638 - Walnut stock LH
- S671-G - ambidextrous hunter green
- S634A - Thumbhole walnut RH
- S637 - Walnut stock RH
- S671 - Ambidextrous traditional
- S671-BHG - Ambidextrous high gloss
- S635A - Thumbhole walnut LH
- S655 - Stock washer
- S625 - Stock screw
- S475 - Filling adaptor

Air Arms, Unit 6, Hailsham Industrial Park, Diplocks
Way, Hailsham, East Sussex, England BN27 3JF.

Tel: 01323 845853. Fax: 01323 440573.

Website: www.air-arms.co.uk

Email: general@air-arms.co.uk